

AB13F

DOUBLE FLANGED BUTTERFLY VALVES
DN50 - DN2000



LEVER OPERATED



GEARBOX OPERATED

FEATURES

- Vulcanized liner resists deformation.
- 316 Stainless steel fasteners.
- Bi-directional bubble-tight sealing, with no leakage under pressure.
- ISO top mounting flange for easy actuation.
- Gearbox fitted as standard on all sizes 200mm and above.

OPTIONS

- Stainless steel lever.
- Gearboxes available for valves 150mm and below.
- Pneumatic and electric actuation.
- Limit switches and positioners.
- Extension fixed and non-fixed.
- Wide selection of body & disc materials:
 - Cast Iron
 - Ductile Iron
 - Aluminium Bronze
 - Stainless Steel
 - Duplex Stainless Steel
 - Other specialty materials on request
- Wide selection of seal materials:
 - EPDM
 - NBR
 - FPM (Viton)
- Drilling to suit a wide range of flanging standards:
 - AS2129 T/E
 - AS4087 CL16 (AS2129 T/D)
 - ANSI
 - EN 1092

TECHNICAL DATA

Size Range:	DN50 - DN2000
Pressure Classes:	PN10 & PN16
Face to face:	According to AS4795
Top Flange:	According to ISO 5211
Flange Drilling:	AS4087 CL16
Temperature Range:	-10°C to +90°C (EPDM standard)
Leakage Tests:	According to AS4795
Coating:	Fusion Bonded Epoxy (AS4020 approved)

AB13F

DOUBLE FLANGED BUTTERFLY VALVES
DN50 - DN2000

DESCRIPTION & MATERIALS

Figure 1. AVFI's AB13F is a Double Flanged Seal on Body Butterfly Valve used extensively in the water and wastewater market.

SS431 STEM CONFIGURATION

Round with key or square
(Depending on size)

EPDM DOUBLE O-RING

Prevents leakage from stem.

PTFE BUSHING

Stem bushing reduces valve torque and prevents stem corrosion.

DOUBLE FLANGED

Drilled to AS4087CL16
(others on request).

EPDM SEAT (LINER)

Vulcanised liner. Other materials available on request.

TOP FLANGE

Top flange as per ISO 5211 standard for simple fitting of lever, gearbox or actuator.

DISC

Precision profile disc provides bubble-tight shut-off and assures minimum torque value and long seal life. (other materials available)

DUCTILE IRON (FUSION BONDED EPOXY COATED) BODY

For superior strength.

CONNECTION BETWEEN DISC & SHAFT

Pin, spline or square connection are all available.

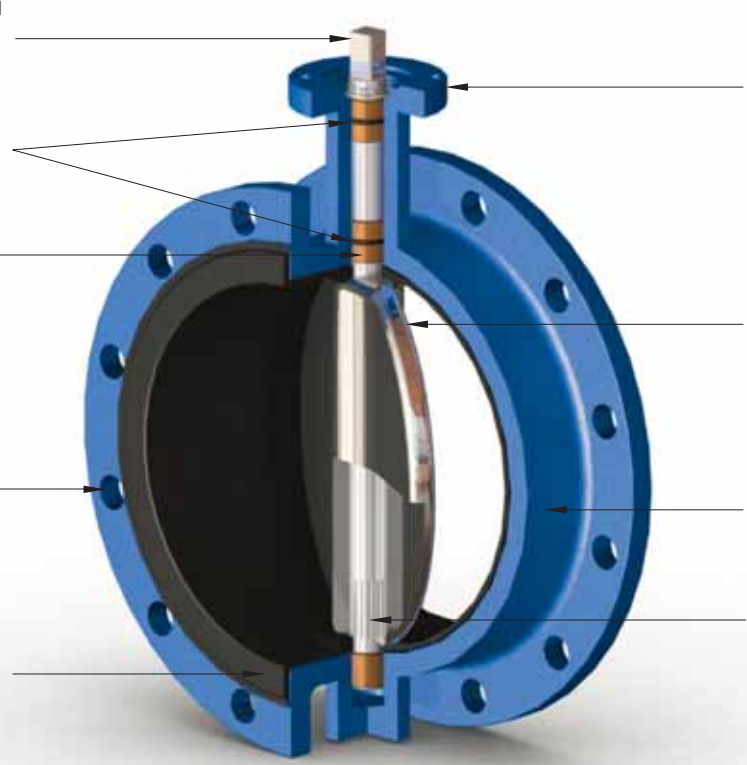

MATERIAL SPECIFICATIONS & PARTS LIST

NO.	DESCRIPTION	MATERIAL
1	Body	Ductile Iron (fusion bonded epoxy coated)
2	Disc	SS316
3	Stem	SS431
4	Bushing	PTFE
5	Seat	EPDM
6	O-Ring	EPDM
7	Pin	SS316

DIMENSIONAL DRAWINGS

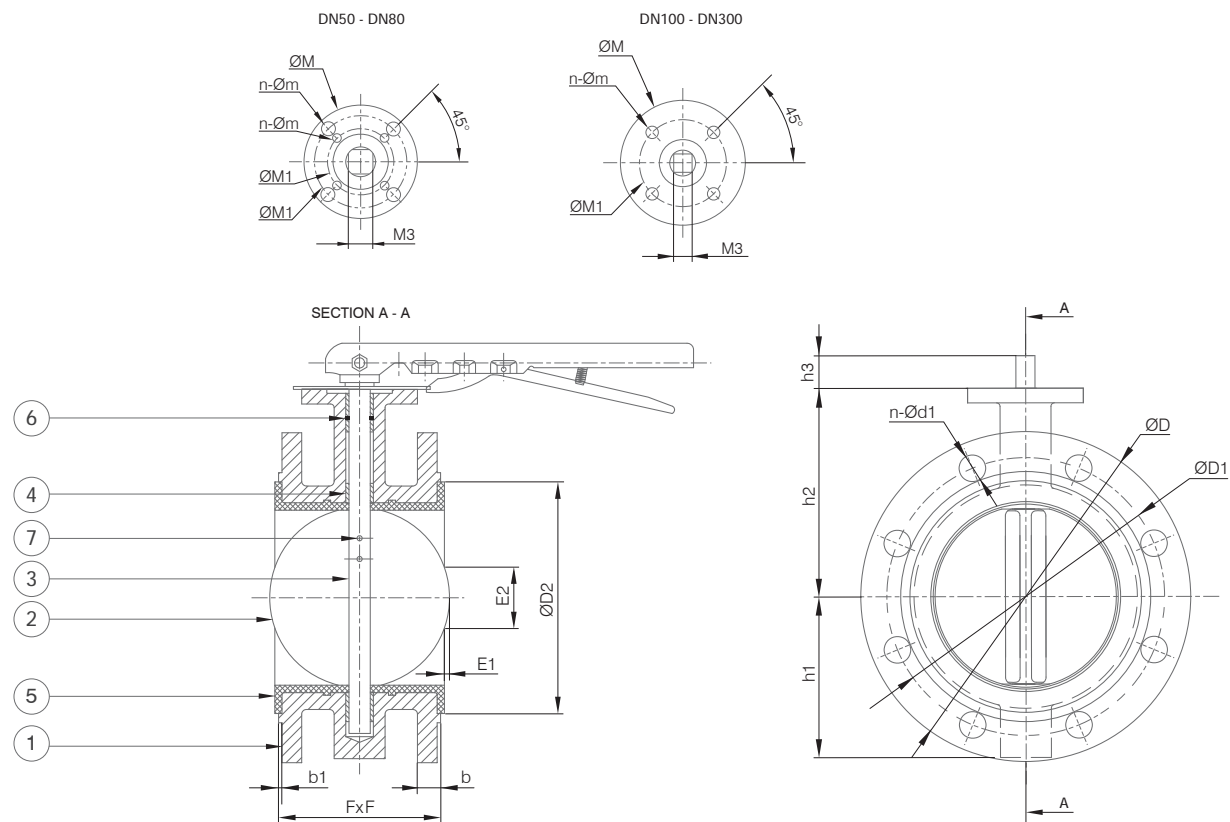

DIMENSIONS (MM)

DN	FxF	b	b1	h1	h2	h3	E1	E2	ØD	ØD1	ØD2	n-Ød1	FLANGE NO.	ØM	n-Øm	ØM1	M3	Weight (kg)
50	108	12	4.5	80	110	29	—	—	150	114	95	4-18	F05/ F07	65/90	4-8	50/70	11 x 11	4.9
65	112	12	4.5	80	134	29	—	—	165	127	114	4-18	F05/ F07	65/90	4-8	50/70	11 x 11	8.2
80	114	12	4.5	95	131	29	—	—	185	146	128	4-18	F05/ F07	65/90	4-8	50/70	11 x 11	10.1
100	127	14	4.5	114	150	29	—	—	215	178	150	4-18	F07	90	4-10	70	11 x 11	13.4
125	140	15	4.5	113	170	29	—	—										
150	140	15	4.5	139	180	29	8.2	69.7	289	235	200	8-18	F07	90	4-10	70	14 x 14	21.5
200	152	16	4.5	175	210	35	25.5	134.4	335	292	262	8-18	F10	125	4-12	102	17 x 17	41.0
250	165	16	4.5	204	248	35	43.3	189.8	405	356	310	8-22	F10	125	4-12	102	22 x 22	53.5
300	178	20	4.5	242	281	35	61.8	243.4	455	406	364	12-22	F10	125	4-12	102	22 x 22	66.4

Note: Flange dimensions may vary from AS4087.
For lever handle dimensions, refer to pg 6.

Designs, materials and specifications shown are subject to change without notice due to our continuing program of product development.
AB13F_V1b_20200602.

All content is protected by Copyright and is owned and/or licensed by AVFI Pty Ltd. Copyright © AVFI Pty Ltd.

AB13F - LEVER

LEVER HANDLE & NOTCH PLATE



Quality
ISO 9001
SAI GLOBAL

MATERIAL SPECIFICATIONS & PARTS LIST

NO.	DESCRIPTION	MATERIAL
1	Body	Ductile Iron (fusion bonded epoxy coated)
2	Disc	SS316
3	Stem	SS431 EPDM
4	Bushing	PTFE
5	Seat	EPDM
6	O-Ring	EPDM
7	Pin	SS316

DIMENSIONAL DRAWINGS

page 4

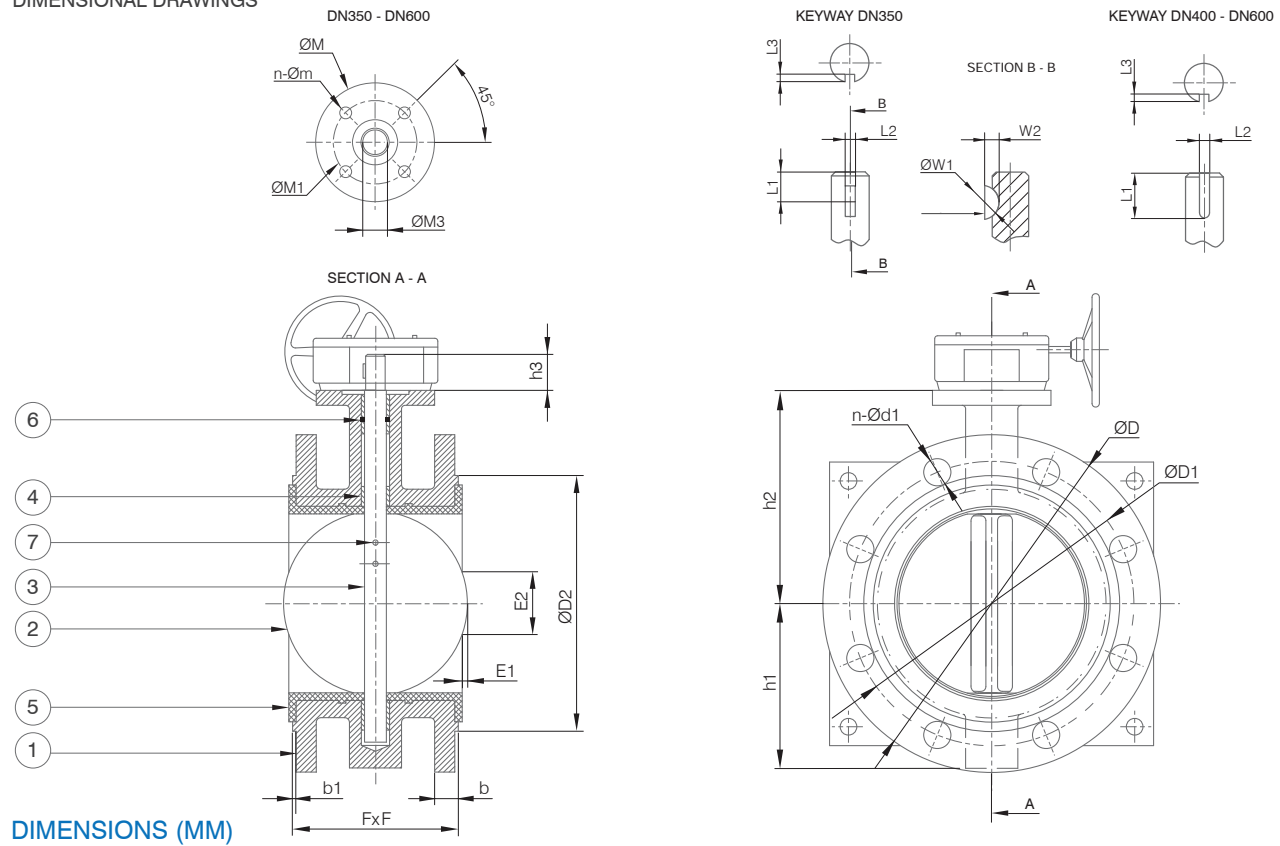

DIMENSIONS (MM)

AB13F DN350 - DN600									AS4087 CL16				ISO 5211 TOP FLANGE					KEYWAY					
DN	FxF	b	b1	h1	h2	h3	E1	E2	ØD	ØD1	ØD2	n-Ød1	FLANGE NO.	ØM	n-Øm	ØM1	ØM3	Weight (kg)	L1	L2	L3	ØW1	W2
350	190	22	5	253	312	45	72	274.6	512	470	422	12-26	F10	125	4-12	102	31.6	84.8	22	8	8	28	11
375	190	23	5	265	350	51.2	79.5	300.3	550	495	450	12-26	F14	175	4-18	140	33.2	121.8	45	10	5	—	—
400	216	23	5	282	343	51.2	87.1	325	570	521	470	12-26	F14	175	4-18	140	33.2	121.8	45	10	5	—	—
450	222	23	5	323	381	51.2	109.6	381.3	620	584	520/538	12-26	F14	175	4-18	140	38	197.8	45	10	5	—	—
500	229	23	5	348	433	64.2	131.5	435.3	655	641	572/599	16-26	F14	175	4-18	140	41.2	279	56	10	5	—	—
600	267	30	5	416	518	70.2	163	529.5	790	756	672/710	16-30	F16	210	4-22	165	50.7	376.8	58	16	6	—	—

Note: Flange dimensions may vary from AS4087.
For gearbox dimensions, refer to pg 7.

MATERIAL SPECIFICATIONS & PARTS LIST

NO.	DESCRIPTION	MATERIAL
1	Body	Ductile Iron (fusion bonded epoxy coated)
2	Disc	SS316
3	Stem	SS431
4	Bushing	PTFE
5	Seat	EPDM
6	O-Ring	EPDM
7	Pin	SS316

DIMENSIONAL DRAWINGS

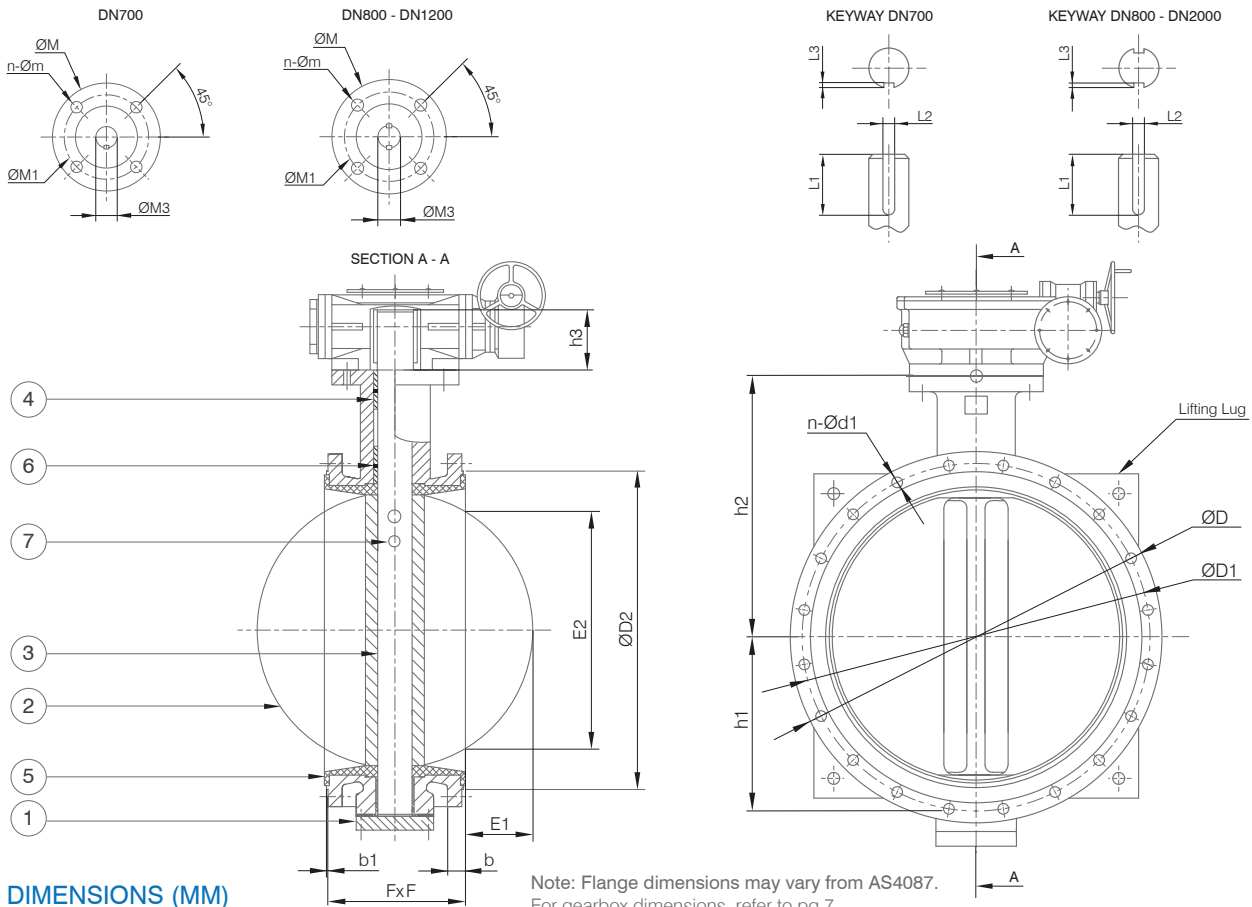

DIMENSIONS (MM)

AB13F DN700 - DN1200									AS4087 CL16				ISO 5211 TOP FLANGE					KEYWAY			
DN	FxF	b	b1	h1	h2	h3	E1	E2	ØD	ØD1	ØD2	n-Ød1	FLANGE NO.	ØM	n-Øm	ØM1	ØM3	Weight (kg)	L1	L2	L3
700	292	26	5	479	562	66	199.9	627.2	910	845	770	20-30	F25	300	8-18	254	55	646	60	16	6
750	305	26	5	474	592	66	214.6	674.3	995	927	855	20-33	F25	300	8-18	254	55	660	60	16	6
800	318	30	5	532	622	66	237.1	725.5	1060	984	871	20-36	F25	300	8-18	254	55	665	60	16	6
900	330	35	6	555	690	118	266	795	1175	1092	972	24-36	F25	300	8-18	254	75	798	110	22	9
1000	410	35	5	674	727	142	275.5	869.2	1255	1175	1080	24-36	F25	300	8-18	254	85	1167	125	22	9
1200	470	45	5	763	917	150	343.1	1056.3	1490	1410	1270	32-36	F30	350	8-22	298	105	1392	150	28	10
1400	530	32	5	900	1000	206	424.5	1273	1700	1615	1530	36-36	F35	415	8-32	356	120	2550	180	32	11
1500	570	36	5	925	1050	206	453	1361.5	—	—	1650	—	F35	415	8-32	356	140	3200	180	36	12
1600	600	36	5	1020	1150	206	488	1457	1910	1825	1750	40-39	F40	415	8-32	356	140	3400	180	36	12
1800	670	40	5	1126	1260	287	553.3	1645.3	2110	2019	1950	44-42	F40	475	8-40	406	160	4050	260	40	13
2000	760	40	5	1320	1363	287	607.5	1823	2560	2460	2150	44-48	F40	475	8-40	406	160	5900	260	40	13

AB13F - LEVER

LEVER HANDLE & NOTCH PLATE



Quality
ISO 9001
SAI GLOBAL

DIMENSIONAL DRAWINGS

Figure 1. Lever handle

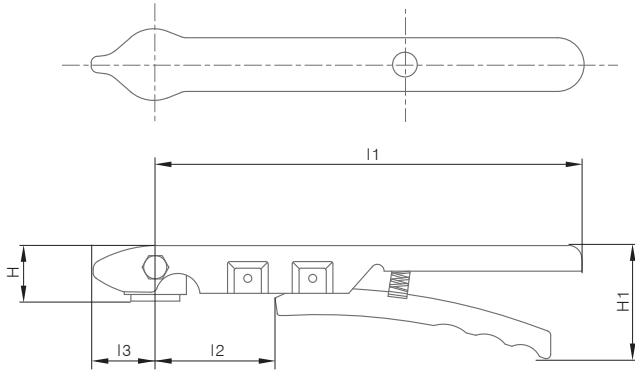

Note: Also available in stainless steel.

Figure 2. Notch plate

DN50 - DN80

DN100 - DN150

DN200 - DN300

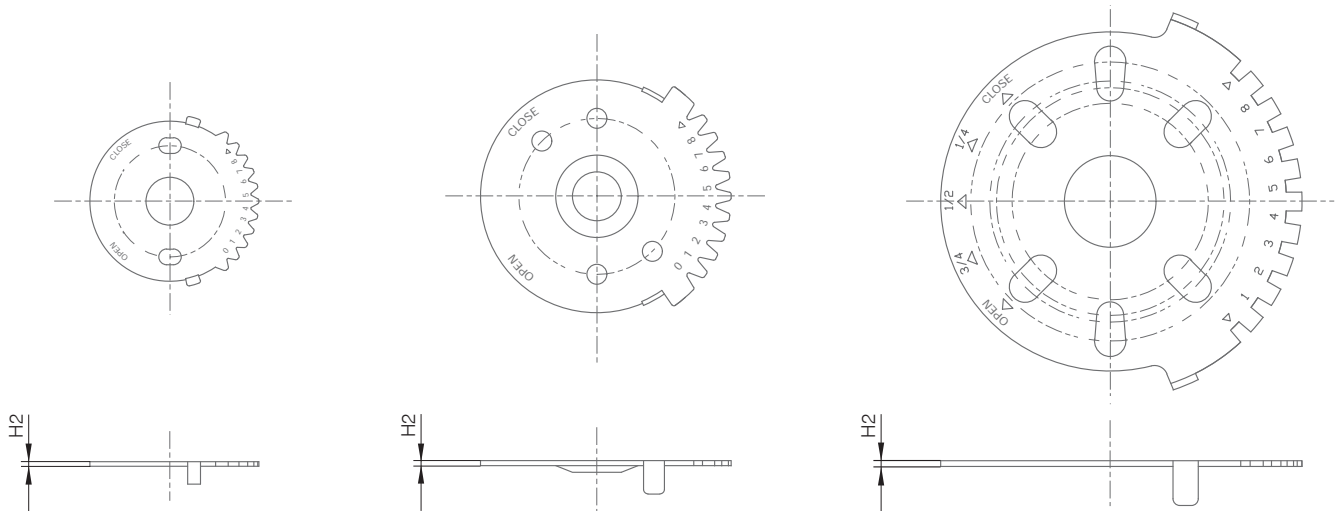

page 6

DIMENSIONS (MM)

DN	LEVER HANDLE					NOTCH PLATE	
	H	H1	I1	I2	I3	FLANGE NO.	H2
40-80	29	55.5	192	37	26.5	F05	2
100-150	29	46	259	54	24	F07	2.5
200-250	33	78	350	81	29	F10	2.5
300	32	73	375	81	25	F10	2.5

Designs, materials and specifications shown are subject to change without notice due to our continuing program of product development. ABU13F_V1b_20200602.

All content is protected by Copyright and is owned and/or licensed by AVFI Pty Ltd. Copyright© AVFI Pty Ltd.

DIMENSIONAL DRAWINGS

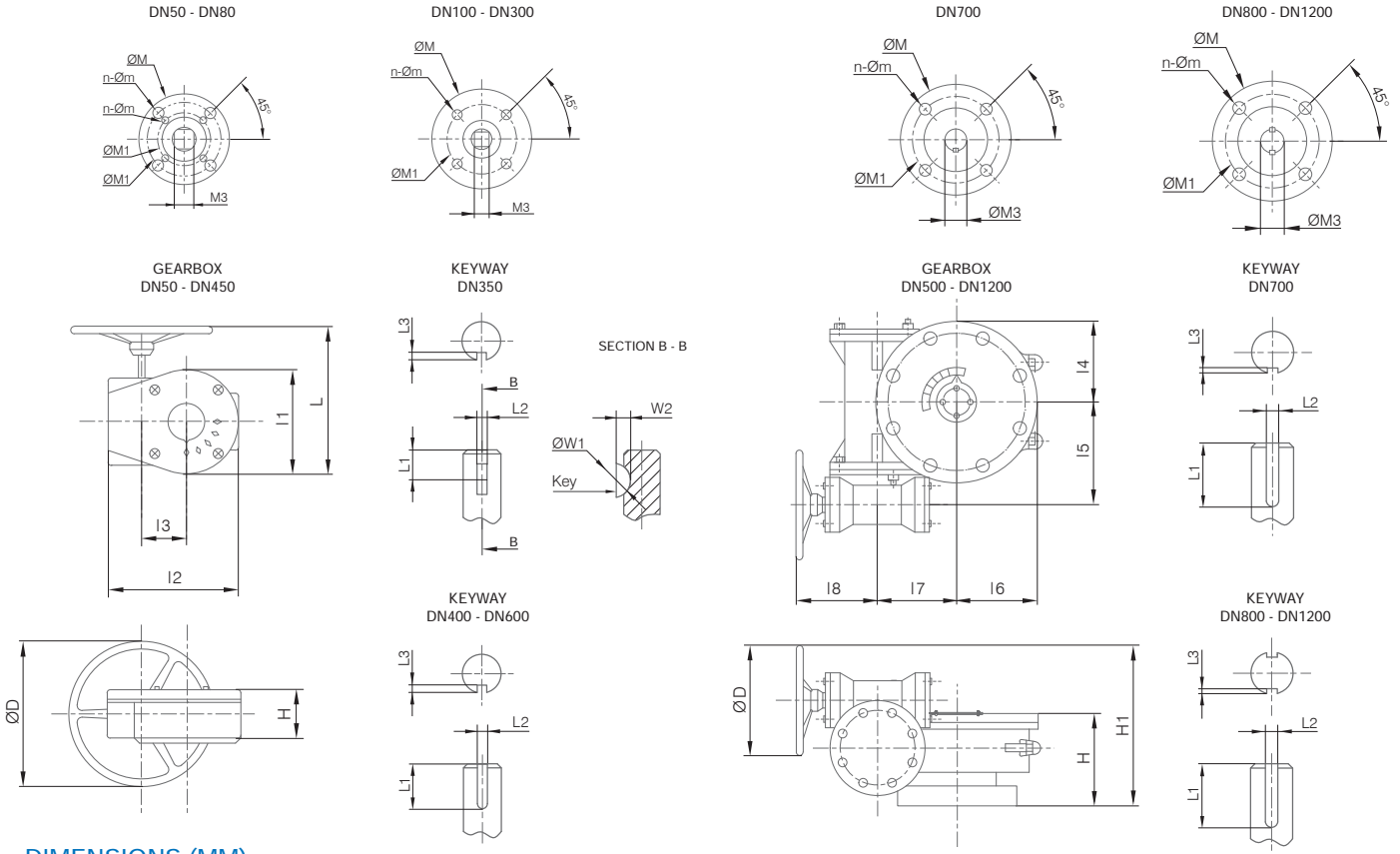

DIMENSIONS (MM)

MODEL	GEARBOX DN50 - DN1200							Max. GB Torque (N.m)	Drive Ratio	Turns	Weight (Kg)	ISO 5211 TOP FLANGE					KEYWAY						
	DN	H	L	I1	I2	I3	ØD					ØM	ØM1	M3	ØM3	n-Øm	L1	L2	L3	ØW1	W2		
3DE-15	50	65	205	106	127	45	150	24:1	6	3.65	146	92	50/70	11x11	-	4-8/4-10	-	-	-	-	-		
3DE-15	65	65	205	106	127	45	150	24:1	6	3.65	146	92	50/70	11x11	-	4-8/4-10	-	-	-	-	-		
3DE-15	80	65	205	106	127	45	150	24:1	6	3.65	146	92	50/70	11x11	-	4-8/4-10	-	-	-	-	-		
3DE-15	100	65	205	106	127	45	150	24:1	6	3.65	146	92	70	11x11	-	4-10	-	-	-	-	-		
3DE-15	125	65	205	106	127	45	150	24:1	6	3.65	146	92	70	14x14	-	4-10	-	-	-	-	-		
3DE-15	150	65	205	106	127	45	150	24:1	6	3.65	146	92	70	14x14	-	4-10	-	-	-	-	-		
3DE-50	200	69	295	145	170	63	500	32:1	8	5.82	287	125	102	17x17	-	4-12	12.7	5	5.5	19	7.5		
3DE-50	250	69	295	145	170	63	500	32:1	8	5.82	287	125	102	22x22	-	4-12	18	8	8	28	11		
3DE-120	300	71	291	156	190	80	1200	50:1	12.5	5.82	287	125	102	22x22	-	4-12	22	8	8	28	11		
3DE-120	350	71	291	156	190	80	1200	50:1	12.5	5.82	287	125	102	-	31.6	4-12	22	8	8	28	11		
3DE-180	400	97	291	249	278	118	1800	80:1	20	20.15	385	175	140	-	33.2	4-18	45	10	5	-	-		
3DE-180	450	97	291	249	278	118	1800	80:1	20	20.15	385	175	140	-	38	4-18	45	10	5	-	-		
MODEL	DN	H	H1	I1	I2	I3	I4	I5	Max. GB Torque (N.m)	Drive Ratio	Turns	Weight (Kg)	ØD	ØM	ØM1	M3	ØM3	n-Øm	L1	L2	L3	ØW1	W2
3D-30/250	500	125	271	107	168	107	100	156	2500	640:1	160	37	285	175	140	-	41.2	4-18	56	10	5	-	-
3D-30/400	600	136	330	131	193	131	125	160	4000	640:1	160	47	385	210	165	-	50.7	4-22	58	16	6	-	-
3D-60/800	700	158	373	173	245	173	162	197	8000	704:1	176	84	425	300	254	-	55	8-18	60	16	6	-	-
3D-60/800	800	158	373	173	245	173	162	197	8000	704:1	176	84	425	300	254	-	55	8-18	60	16	6	-	-
3D-120/1500	900	185	409	201	279	201	196	203	15000	748:1	187	110	425	300	254	-	75	8-18	110	22	9	-	-
3D-120/1500	1000	185	409	201	279	201	196	203	15000	748:1	187	145	425	300	254	-	85	8-18	125	22	9	-	-
3D-120/2500	1200	216	423	255	311	185	240	203	25000	850:1	212.5	205	425	350	298	-	105	8-22	150	28	10	-	-

AB13F

DOUBLE FLANGED BUTTERFLY VALVES
DN50 - DN1200



TORQUE VALUE AT PRESSURE CONDITION

VALVE SIZE (DN)		CLOSE-OFF TORQUE	
mm	inch	PN10	PN16
50	2"	11	12
65	2.5"	14	17
80	3"	18	22
100	4"	39	50
125	5"	63	78
150	6"	80	95
200	8"	96	110
250	10"	225	285
300	12"	254	355
350	14"	572	676
400	16"	648	843
450	18"	989	1286
500	20"	1237	1608
600	24"	2472	3214
700	28"	5000	5400
750	30"	5100	6264
800	32"	5100	6264
900	36"	6308	9463
1000	40"	9818	12764
1200	42"	12555	16321

Note: All torque value in left chart were derived from the actual test data using water at 20°C. For torque used in other media, please contact AVFI directly. Torques shown do not include safety factor.

For actuator selection, AVFI recommends:

- For EPDM, NBR, VITON seat, these valves be multiplied by 1.35 to 1.5 for single valve applications.

Kindly note under certain conditions, hydrodynamic torque can meet or exceed seating and unseating torques.

FLOWRATE

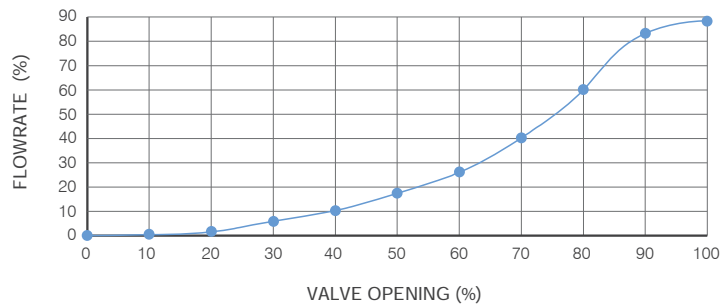

Note: Sizes DN1400 and above available on request.

CV VALUES FOR AB SERIES

VALVE SIZE (DN)		CV VALUE									
mm	inch	10%	20%	30%	40%	50%	60%	70%	80%	90%	
40	1 1/2	0.06	3	7	14	25	36	51	70	76	
50	2	0.1	5	12	24	45	64	90	125	135	
65	2 1/2	0.2	8	20	37	65	98	144	204	220	
80	3	0.3	12	22	39	70	116	183	275	302	
100	4	0.5	17	36	78	139	230	364	546	600	
125	5	0.8	29	61	133	237	392	620	930	1022	
150	6	2	45	95	205	366	605	958	1437	1579	
200	8	3	89	188	408	727	1202	1903	2854	3136	
250	10	4	151	320	694	1237	2047	3240	4859	5340	
300	12	5	234	495	1072	1911	3162	5005	7507	8250	
350	14	6	338	715	1549	2761	4568	7230	10844	11917	
400	16	8	464	983	2130	3797	6282	9942	14913	16388	
450	18	11	615	1302	2822	5028	8320	13168	19752	21705	
500	20	14	791	1674	3628	6465	10698	16931	25396	27908	
550	22	17	965	2042	4426	7887	13052	20655	30983	34048	
600	24	22	1222	2587	5605	9989	16528	26157	39236	43116	
650	26	26	1434	3036	6578	11723	19397	29263	46047	50600	
700	28	30	1663	3522	7630	12599	20036	30482	46899	58696	
750	30	35	1912	4050	8142	13152	20411	31226	47562	63328	
800	32	45	2387	4791	8736	13788	20613	31395	48117	68250	
850	34	51	2697	5414	9872	15580	23293	35476	54372	77123	
900	36	60	3021	6063	11055	17449	26086	39731	60895	86375	
1000	40	84	4183	8395	15307	24159	36166	55084	84425	119750	
1050	42	350	4095	9040	17108	27150	43640	70500	106890	117500	
1200	48	455	5365	11840	22400	30600	51200	92300	140000	154000	

Note: Sizes DN1400 and above available on request.

Designs, materials and specifications shown are subject to change without notice due to our continuing program of product development. ABU13F_V1b_20200602.

All content is protected by Copyright and is owned and/or licensed by AVFI Pty Ltd. Copyright © AVFI Pty Ltd.