

ASF10

SPHERICAL RUBBER EXPANSION JOINT



FEATURES

- Minimal axial dimensions.
- Limited Weight.
- Low warping forces.
- High-resistance to work.
- High-capacity acoustic damping.

OPTIONS

- Other rubber materials such as Hypalon, Nitrile, Neoprene & Viton available on request.
- Stainless steel retaining rings.
- Threaded barrel union connections.
- Reducer type.
- Control arms.
- Limit rods.
- DIN drilled one end and AS2129 other end.
- PN10 & PN25 pressure rating.

TECHNICAL DATA

Size Range:	DN32 - DN600 (other sizes available on request)
Pressure Range:	PN16 (Standard) PN10 (On Request) PN25 (On Request)
Vacuum:	PN16 650mmHg (Standard) PN10 400mmHg (On Request) PN25 750mmHg (On Request)
Temperature Range:	- 20°C to +200°C (depending on tube material, refer page 2)
Drilling Pattern:	AS2129 T/E (Standard) AS4087 CL16 (On Request) DIN/AS2129 combination (On Request) (others available on request)
Pressure Tests:	3 times maximum rated pressure

ASF10

SPHERICAL RUBBER EXPANSION JOINT

DESCRIPTION & MATERIALS

COVER

This is the exterior surface of the expansion joint, compounded of EPDM compounds to withstand aging, cracking and corrosion.

TUBE

The tube is a single piece of leak-proof lining extending end to end. EPDM as standard, it can be supplied in NBR, CR, Nitrile, NR, Hypalon, Viton or other compounds on request. All of our rubber compounds are specifically formulated to provide maximum sound and heat insulation as well as abrasion resistance.

RETAINING RINGS

Retaining rings are made of zinc coated mild steel as standard, with other materials such as 316 stainless steel available on request.

FABRIC INTERLINER

This is a strong, bias-ply construction, high-strength woven polyester reinforcing fabric between tube and cover.

REINFORCEMENT RINGS

Round steel rings embedded in the fabric interliner give maximum strength to the expansion joint while under pressure or vacuum service.

NO GASKET

The tube extends through the retaining rings to create a gasket that is an integral part of the expansion joint to insure a tight reliable seal. No further gaskets are necessary.

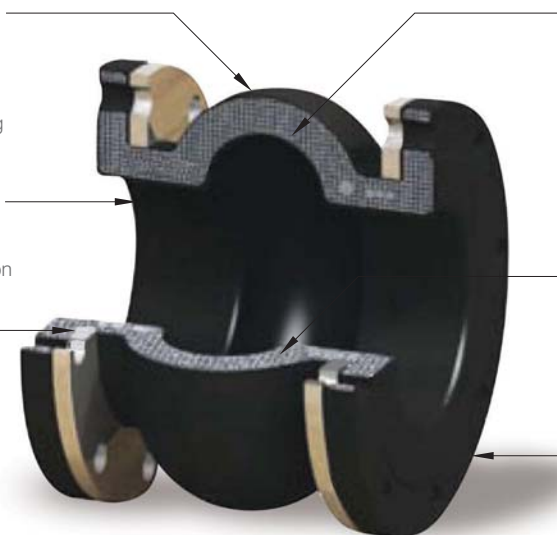

ELASTOMER SELECTION GUIDE

ELASTOMER TUBE & COVER	MIN. & MAX. TEMPERATURE	SUITABLE MATERIAL	NON SUITABLE MATERIAL
Ethylene Propylene (EPDM)	-10°C to +105°C	Steam, warm and cold water, drinking water, compressed air without oil lubricants, vegetable oils, ozone, alcohols & ketones.	Mineral oils, solvents, aromatic hydrocarbons.
Hypalon (CSM)	-20°C to +120°C	Strong acids and bases, freons, hydroxides, ozone, alcohols, alkaline & hypochlorite solutions.	Ketones, esters, certain chlorinated oxidizing acids, nitro & aromatic hydrocarbons.
Neoprene (CR)	-10°C to +105°C	Warm and cool water, drinking water, moderator acids, ozone.	Oxidizing acids, esters, ketones & aromatic nitro hydrocarbons.
Buna N (NBR)	-10°C to +80°C	Most hydrocarbons, fats, oil greases, hydraulic fluids & solvents.	Ozone, ketones, esters, aldehydes nitro & chlorinated hydrocarbons.
Viton (FKM)	-20°C to +200°C	All aliphatic, aromatic and halogenated hydrocarbons, many acids, animal and vegetable oils.	Ketons, esters & chlorine.

MATERIAL SPECIFICATIONS & PARTS LIST

NO.	DESCRIPTION	MATERIAL
1	Cover	EPDM
2	Reinforcing Fabric	Nylon
3	Tube	EPDM
4	Reinforcement Rings	Zinc plated steel
5	Retaining Rings	Zinc plated steel (standard) Stainless steel (optional)

DIMENSIONS (MM)

ASF10 DN32-DN600		AS2129 T/E AS4087 CL16		AS2129 T/E		AS4087 CL16 (on request)		MOVEMENTS			
DN	FxF	b	ØD	ØD1	n-Ød1	n-Ød1	n-Ød1	Axial Elong.	Axial Comp.	Lateral	Angular (°C)
32	95	15	120	87	4-14	4-14	4-14	4	8	8	15
40	95	15	135	98	4-14	4-14	4-14	4	8	8	15
50	105	15	150	114	4-18	4-18	4-18	5	8	8	15
65	115	15	165	127	4-18	4-18	4-18	6	12	10	15
80	130	17	185	146	4-18	4-18	4-18	6	12	10	15
100	135	17	215	178	8-18	4-18	4-18	10	18	12	15
125	165	19	255	210	8-18	8-18	8-18	10	18	12	15
150	180	21	280	235	8-22	8-18	8-18	10	18	12	15
200	205	21	335	292	8-22	8-18	8-18	14	25	22	15
250	240	23	405	356	12-22	8-22	8-22	14	25	22	15
300	260	25	455	406	12-26	12-22	12-22	14	25	22	15
350	265	25	525	470	12-26	12-26	12-26	16	25	22	15
400	265	27	580	521	12-26	12-26	12-26	16	25	22	15
450	265	29	640	584	16-26	12-26	12-26	16	25	22	15
500	265	29	705	641	16-26	16-26	16-26	16	25	22	15
600	265	29	825	756	16-33	16-30	16-30	16	25	22	15

APPLICATIONS

- Compensate for heat-generated expansions.
- Compensate for the settlements of terrain or building structures.
- Compensate for rolling movements and assembly errors.
- Absorb machinery vibrations and reduce the noise they produce.
- Soften the impact of water hammers.
- Create disassembly joints.
- Suitable for pressure or suction duty.
- Can be fitted between tank and pipe work.

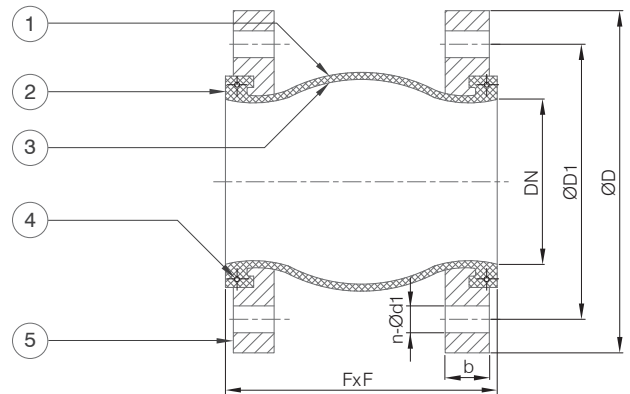
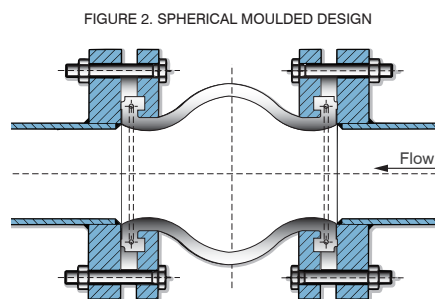
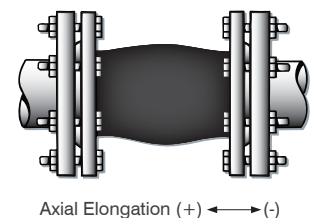
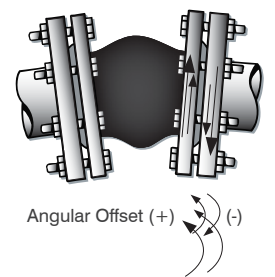
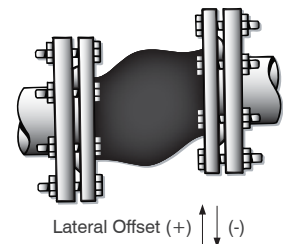
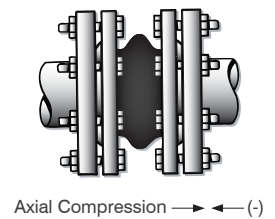

FIGURE 1. MOVEMENTS



ASF10

SPHERICAL RUBBER EXPANSION JOINT

CONTROL - UNITS

Generally control-units are always recommended as an additional safety factor, preventing damage to the joint and the associated equipment.

FEATURES

- Protects expansion joints from over expansion and over compression.
- High tensile galvanized steel rods (stainless steel and other materials available on request).
- Galvanized gusset plates (stainless steel and other materials available on request).
- Rubber grommets isolate vibration and are standard for all sizes.
- Spherical washers are available to prevent binding while minimizing lateral forces.
- Double nuts are used to lock limit points to allow field adjustments.
- Other standard drillings available include DIN, BS, EN, UNI, JIS and ANSI etc.
- Universal tied/ self guiding control units are available to prevent movement on longer expansion joints.

SUGGESTIONS FOR INSTALLATION & MAINTENANCE

1. Clean all foreign matter and remove burrs or sharp edges from flanges.
2. All pipe lines should be properly supported so that the expansion joints do not carry the pipe load.
3. Do not install joints on raised face flanges of more than 1/16".
4. All pipes are to be lined up accurately before installing expansion joints.
5. Bolts should be on the inside of the joint flange. Metal washers must be placed at the facing of the split retaining ring.
6. Bolts should be tightened, alternating around the flange.
7. Bolt tightness should be checked one week after going on stream and periodically thereafter.
8. If the system is not anchored to insure against movement beyond maximum stated limits, a control unit must be used.

WITH LIMIT ROD



WITH CONTROL ROD



FIGURE 3. INSTALLATION EXAMPLE

