

TECHNICAL DATA

Size Range:	DN50 - DN600*
Pressure Class	PN16
Face to Face:	AS/NZS 2638.2:2011
Flange Drilling:	AS4087 B5
Pressure Testing:	AS/NZS 2638.2:2011
Coating:	AS4020 Approved
Operator:	Keycap (standard)
ISO Mount:	Standard for DN350 & above

OPTIONS

- Clockwise (CC) or Anti-Clockwise (ACC) close.
- Handwheel, gear box or electric actuator operation available.
- Spindle extensions.

MATERIAL SPECIFICATION & PARTS LIST

NO.	DESCRIPTION	MATERIAL
1	Body	Ductile Iron 500-7 (AS1831)
2	Wedge	EPDM (AS1646) Encapsulated Ductile Iron 500-7 (AS1831)
3	Stem	Stainless Steel 431
4	Stem Nut	Alu. Bronze (C95210)
5	Bonnet Gasket	EPDM (AS1646)
6	Bolt	Stainless Steel 316
7	Bonnet	Ductile Iron 500-7 (AS1831)
8	V Sealing	NBR (AS1646)
9	Washer	Nylon
10	O-Ring	NBR (AS1646)
11	Bonnet Gland	Alu. Bronze (C95210)
12	O-Ring	NBR (AS1646)
13	Dust Guard	NBR (AS1646)
14	Cap	Ductile Iron 500-7 (AS1831)
15	Bolt	Stainless Steel 316
16	Top Flange	Ductile Iron 500-7 (AS1831)

APPROVED TO

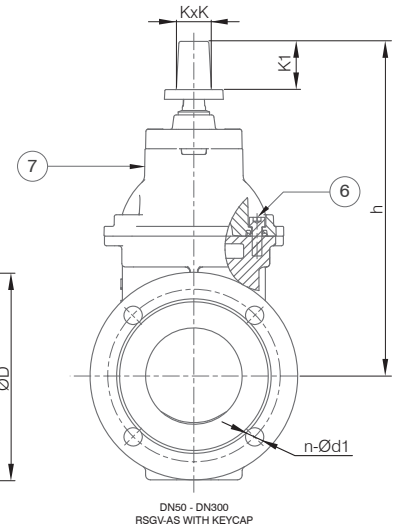
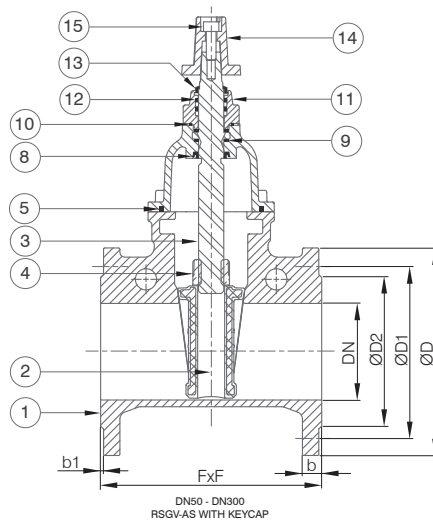
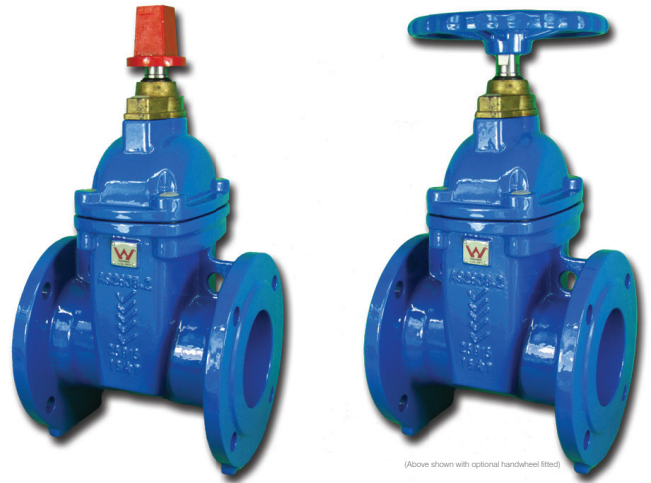

DIMENSIONS (MM)

RSGV-AS DN50 - DN600							KEY CAP		FLANGE DRILLING			AS4087 CL16	AS2129 T/E	OPERATIONAL DATA			
DN	FxF	b	b1	h	h1	h2	K1	KxK	ØD	ØD1	ØD2	n-Ød1	n-Ød1	Closure Turns	Torque (NM)	Weight (Kg)	Top Flange
50*	178	18	3	300	—	—	—	—	150	114	90	4-18	4-18	12	35	11	—
65*	190	18	3	310	—	—	—	—	165	127	103	4-18	4-18	12	40	12	—
80	203	18	3	318	—	—	50	35x35	185	146	122	4-18	4-18	19	75	18	—
100	229	20	3	350	—	265**	50	35x35	215	178	154	4-18	8-18	23	100	24	F10**
150	267	23	3	440	—	347**	50	35x35	280	235	211	8-18	8-22	32	150	44	F10**
200	292	23	3	550	—	434**	57	35x35	335	292	268	8-18	8-22	35	200	69	F14**
225	305	24	3	590	—	—	57	35x35	370	324	300	8-18	12-22	43	200	105	—
250	330	24	3	622	—	525**	57	35x35	405	356	328	8-22	12-22	44	250	111	F14**
300	356	30	4	706	—	606**	57	35x35	455	406	378	12-22	12-26	53	300	150	F14**
350	381	33	4	—	962	807	57	35x35	525	470	438	12-26	12-26	35	450	210	F16
375	381	33	4	—	985	912	57	35x35	550	495	463	12-26	12-26	39	500	281	F16
400	406	33	4	—	1068	912	57	35x35	580	521	489	12-26	12-26	39	550	306	F16
450	432	33	4	—	1135	984	57	35x35	640	584	552	12-26	16-26	41	600	363	F16
500	457	35	4	—	1254	1060	57	35x35	705	641	609	16-26	16-26	47	660	442	F16
600	508	42	5	—	1410	1232	57	35x35	825	756	720	16-30	16-33	50	800	607	F16

(*DN50-DN65 not covered by AS/NZS 2638.2:2011)

(** ISO mount optional extra for sizes DN100-300)

