

FEATURES

- All 316 stainless steel construction.
- Polished float.
- Pressure range up to 1000Kpa.
- Silicone seat.
- Working temperature up to 150°C.
- Fullbore for high flow.
- BSP standard connection (NPT on request)



TECHNICAL DATA

Size Range:	DN15 - DN65
Pressure Classes:	PN10
Temperature Range:	-20°C to +150°C
Connections:	DN15 - DN65 Threaded BSP

DIMENSIONS (MM)

G-FV-SS							
DN	I1	I2	ØD (inch)	ØD1	h1 (Closed)	h2 (Opened)	Weight (Kg)
15	410	35	1/2"	110	127	375	0.55
20	500	42	3/4"	160	155	436	1.00
25	580	45	1"	160	174	521	1.05
32	580	52	1 1/4"	160	164	520	1.25
40	620	60	1 1/2"	200	253	651	3.45
50	720	70	2"	200	255	736	3.75
65	720	80	2 1/2"	200	277	737	4.40

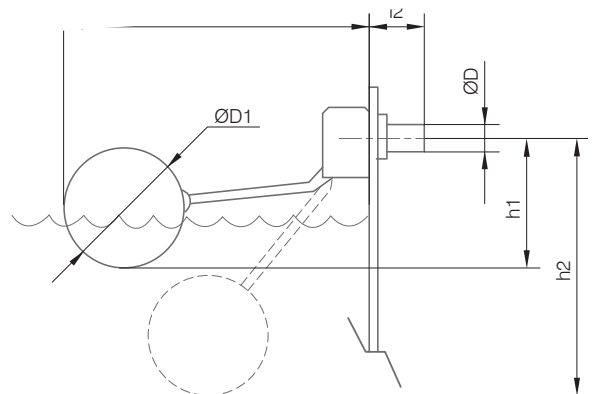

FLOWRATE (LITRES PER HOUR)

PRESSURE (Bar)							
DN	1	2	3	4	6	8	10
15	2829	3998	4895	5657	6790	7978	8938
20	4838	6842	8370	9677	11805	13993	15289
25	6934	9919	12147	14068	17167	19654	21945
32	10176	15438	19438	23154	28908	33594	38168
40	15566	21948	26928	31104	37635	43657	51516
50	23685	33863	40997	47372	57791	67532	75500
65	24869	35556	43025	49740	60680	70908	79275