

## TECHNICAL DATA

Size Range:	DN50 - DN800
Pressure Class	PN16
Face to face:	AS2638.2 - 2011 (DN80-DN600)
Flange Drilling:	AS4087 B5
Pressure Testing:	AS2638.2 - 2011
Coating:	AS4020

## OPTIONS

- Handwheel, keycap, gear box or electric actuator operation available.
- Spindle extensions

## MATERIAL SPECIFICATION & PARTS LIST

NO.	DESCRIPTION	MATERIAL
1	Body	Ductile Iron
2	Wedge	EPDM Encapsulated Ductile Iron
3	Stem	Stainless Steel
4	Stem Nut	Bronze Alloy
5	Bonnet Gasket	EPDM
6	Bolt	Stainless Steel
7	Bonnet	Ductile Iron
8	Lip Seal	EPDM
9	Washer	Nylon
10	Bushing Nut	Bronze Alloy
11	O-Ring	EPDM
12	O-Ring	EPDM
13	Dust Guard	EPDM
14	Cap	Ductile Iron
15	Top Nut	Stainless Steel
16	Top Flange	Ductile Iron
17	Key	Stainless Steel
18	Handwheel	Ductile Iron

## DIMENSIONAL DRAWINGS

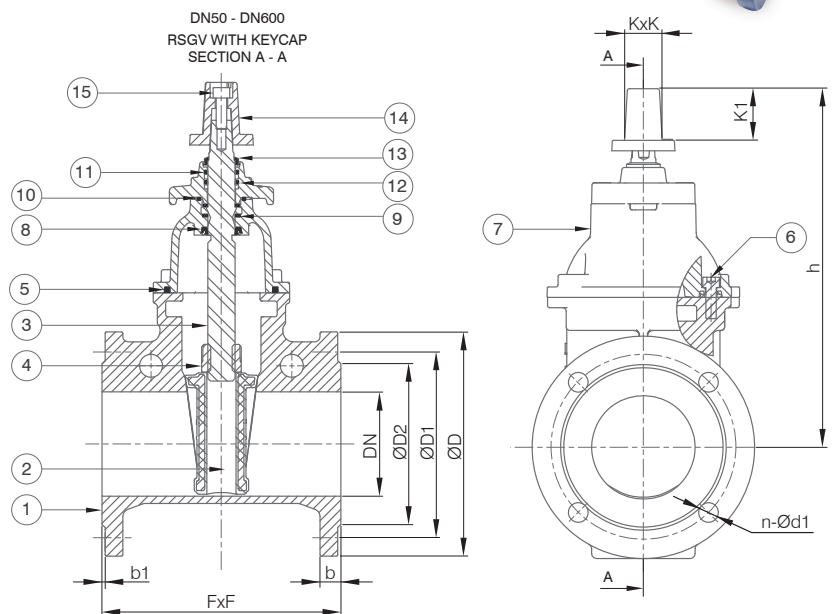

## DN350 - DN600 RSGV WITH HANDWHEEL

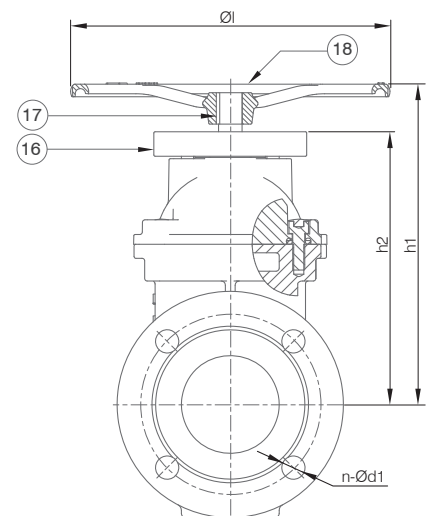

## DIMENSIONS (MM)

RSGV DN50 - DN600															
DN	FxF	b	b1	h	K1	KxK	ØD	ØD1	ØD2	n-Ød1	ØI	h1	Closure Turns	Min. closing torque at PN16 (n.m)	Weight (Kg)
50	178	18	3	300	50	35x35	150	114	90	4-18	180	270	19	35	9
65	190	18	3	310	50	35x35	165	127	103	4-18	180	280	19	40	13
80	203	18	3	320	50	35x35	185	146	122	4-18	200	290	19	40	16
100	229	20	3	345	50	35x35	215	178	154	4-18	200	315	23	50	23
150	267	23	3	440	50	35x35	280	235	211	8-18	280	410	32	80	43
200	292	23	3	545	57	35x35	335	292	268	8-18	320	515	35	150	67
225	305	24	3	590	57	35x35	370	324	300	8-18	320	560	43	210	90
250	330	24	3	635	57	35x35	405	356	328	8-22	320	605	44	220	101
300	356	30	4	725	57	35x35	455	406	378	12-22	450	695	53	240	148
350	381	33	4	820	57	35x35	525	470	438	12-26	450	823	35	300	206
375	381	33	4	910	57	35x35	550	495	463	12-26	450	950	37	360	278
400	406	33	4	1000	57	35x35	580	521	489	12-26	560	922	39	400	302
450	432	33	4	1075	57	35x35	640	584	552	12-26	560	994	41	400	359
500	457	35	4	1150	57	35x35	705	641	609	16-26	800	1104	47	550	439
600	508	42	5	1350	57	35x35	825	756	720	16-30	800	1274	50	600	604

DN350 - DN600 WITH ISO 5211 TOP FLANGE												
DN	h2	h3	h4	FLANGE NO.	ØM	ØM1	ØM2	ØM3	L1	L2	L3	
350	718	80	4.5	F16	175	140	100	42	70	12	5	
375	818	80	5.5	F16	210	165	130	42	70	12	5	
400	818	80	5.5	F16	210	165	130	42	70	12	5	
450	890	80	5.5	F16	210	165	130	42	70	12	5	
500	970	110	5.5	F25	300	254	200	48	85	14	5	
600	1144	110	5.5	F25	300	254	200	48	85	14	5	

### DIMENSIONAL DRAWINGS

DN350 - DN600  
RSGV WITH ISO TOP FLANGE

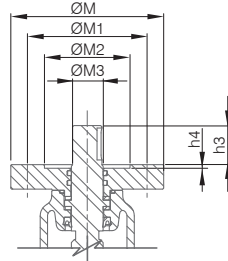

KEYWAY

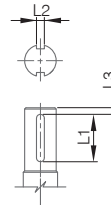

### MATERIAL SPECIFICATION & PARTS LIST

NO.	DESCRIPTION	MATERIAL
1	Body	Ductile Iron
2	Wedge	Ductile Iron
2	Wedge Rubber	EPDM
3	Stem	Stainless Steel
4	Stem Nut	Bronze Alloy
5	Bonnet Gasket	EPDM
6	Bolt	Stainless Steel
7	Bonnet	Ductile Iron
8	O-Ring	NBR
9	O-Ring	NBR
10	O-Ring	NBR
11	Bushing	Bronze
12	O-Ring	NBR
13	Bearing	Proprietary
14	O-Ring	NBR
15	Bushing	Bronze
16	O-Ring	NBR
17	Seal Retainer	Ductile Iron
18	Double End Bolt	Stainless Steel
19	Acorn Nut	Stainless Steel
20	Plain Washer	Stainless Steel
21	Manual Driving Device	Proprietary
22	Top Bonnet Bolt	Stainless Steel
23	Eye Bolts	Carbon Steel with galvanization

### DIMENSIONAL DRAWINGS

DN700 - DN800  
RSGV WITH GEARBOX  
SECTION A - A

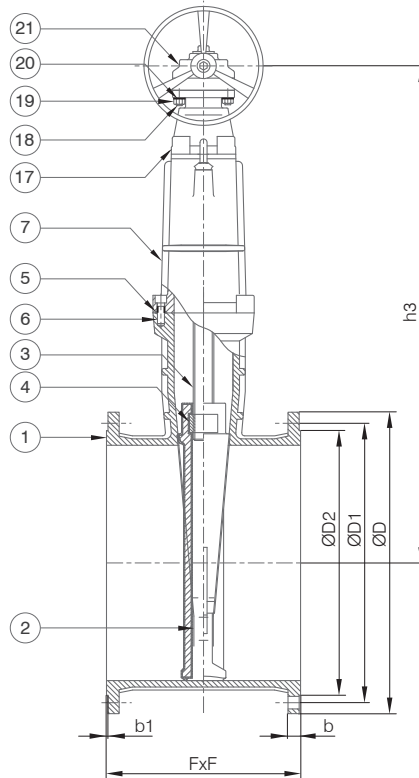

RSGV WITH BARE SHAFT

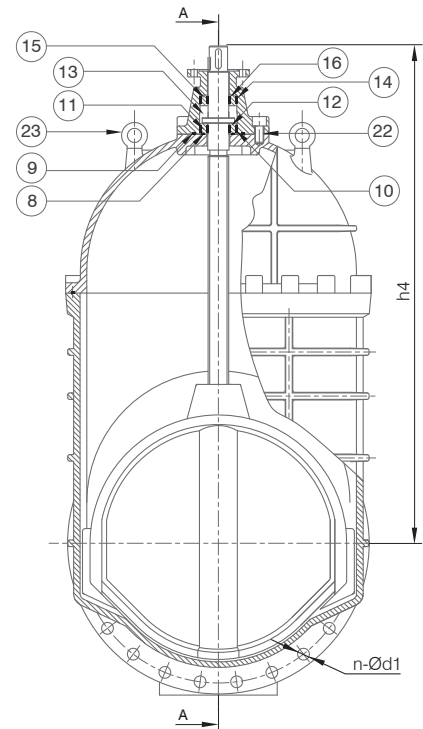

### DIMENSIONS

RSGV DN700 - DN800												
DN	FxF	b	b1	h3	h4	ØD	ØD1	ØD2	n-Ød1	Closure Turns	Bare Shaft Torque (n.m)	Weight (Kg)
700	610	45	5	1580	1500	910	845	809	20-30	80	1200	885
750**	660	48	5	1690	1690	995	927	888	20-33	82	1800	1197
800	660	48	5	1690	1690	1060	984	942	20-36	82	1800	1197

Note: For sizes DN900, 1050, 1200 & 1500, see separate data sheet.  
\*\*DN750 is a DN800 RSGV with drilling to suit DN750 drilling pattern

Designs, materials and specifications shown are subject to change without notice due to our continuing program of product development.  
RSGV\_V3\_20140729

All content is protected by Copyright and is owned and/or licensed by AVFI Pty Ltd. Copyright© AVFI Pty Ltd.