

FACTORY ACCREDITED:



TECHNICAL DATA

Size Range:	10mm - 50mm
Suitable for:	Water, air and oil under 20 CST
Maximum Temperature:	120°C (fluid only)
Voltages available:	24VAC, 240VAC, 12VDC, 24VDC, 110VAC
Connections:	BSPF (standard) NPT or flanged (optional)

The AZS range is a direct acting solenoid valve that will work from zero (0) pressure and is available in brass or stainless steel. Models include AZS which is normally closed (energise to open) or AZSH normally open (energise to close).

All models feature investment cast body, interchangeable coils and Viton diaphragm.

FEATURES

- Normally closed & normally open models.
- Brass or stainless steel body materials.
- Viton diaphragm, others available on request.
- LED din plug available.
- All voltages interchangeable.

PRESSURE LOSS CHART

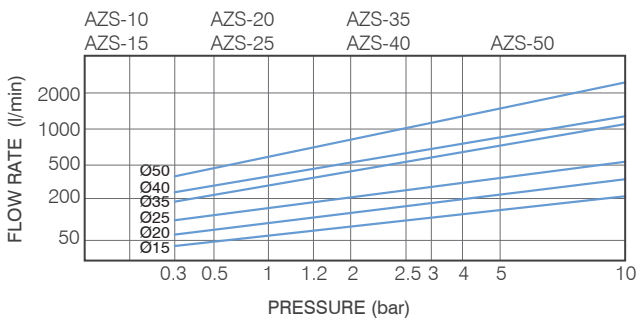

AZS-316



AZSH

PARTS LIST

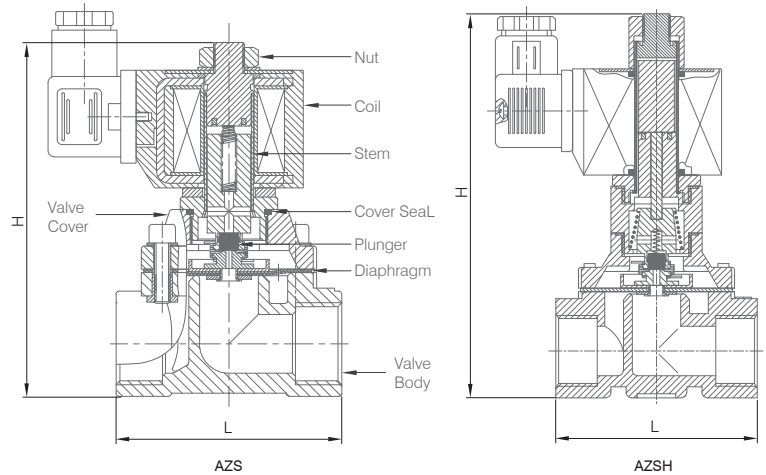

DIMENSIONS

MODEL	FUNCTION	BODY MATERIAL		SIZE (MM)	L x H (MM)	CV FACTOR
AZS & AZS-316	Normally Closed	AZS (Brass)	AZS-316 (SS316)	10	69 x 107	4.8
				15	69 x 107	4.8
				20	73 x 115	7.6
				25	99 x 121	12
				32	112 x 148	24
				40	123 x 158	29
AZSH & AZSH-316	Normally Open	AZSH (Brass)	AZSH-316 (SS316)	10	69 x 130	4.8
				15	69 x 130	4.8
				20	73 x 138	7.6
				25	99 x 146	12
				32	112 x 192	24
				40	123 x 203	29
50	165 x 226	48				

SELECTION LIST

MODEL & SIZE (MM)	MINIMUM PRESSURE	OPERATING PRESSURE BAR (AIR)		OPERATING PRESSURE BAR (WATER)		OPERATING PRESSURE BAR (OIL)		POWER CONSUMPTION		COIL TYPE & CODE (D=DIN PLUG)			
		AC	DC	AC	DC	AC	DC	24/240VAC (VOLT AMPS)	12/24VDC (WATTS)	240VAC	24VAC	24VDC	12VDC
AZS & AZS-316 10 - 25 32 - 50	0	10	6	10	6	7	4	48/20	20	D01-41014	D01-4104	D01-4106	D01-4107
	0	10	6	10	6	7	4	70	40	D08-61014	D08-6104	D08-6106	D08-6107
AZSH & AZSH-316 10 - 25 32 - 50	0	5	5	5	5	3	3	48/20	28.5/20	D01-41014	D01-41014	D01-4104	D01-4106
	0	5	5	5	5	3	3	70	40	D08-61014	D08-61014	D08-6104	D08-6106