



Product Catalogue

**DAV - MP**

# DAV - MP

## Metallic-Shield Air Valves

**DAV - MP**  
(Metallic-Shield Air Valves)



**General**

The presence of trapped air in a pressurized pipeline can have serious effects on system operation and efficiency.

As air pockets accumulate at high points, they reduce the effective cross-section of the pipeline in their location, decreasing the water flow, and increasing energy consumption required to pump the water through. Thus reducing the overall system efficiency. A pipeline with many air pockets may impose enough restriction to stop all flow ("airlocks").

The dislodge and movement of the air pockets may change suddenly the fluid velocity and cause pressure surges and pipeline ruptures.

Trapped air pockets may also accelerate corrosion in the pipe material, damage water metering devices and cause erratic operation of control valves.

On the other hand, when a system is being drained there is a necessity to admit atmospheric air into the pipeline in order to occupy the volume of drained water so to prevent dangerous sub-atmospheric pressure in the pipeline that may bring to complete collapse of pipe-sections.

**Pipeline Without Air-Release Valves**

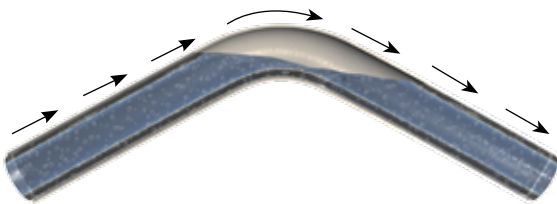

Pressurized air may be trapped at local high points of the pipeline

- Increases head loss
- Decreases flow rate
- Increases energy consumption

**Pipeline Without Kinetic Vacuum Valve**

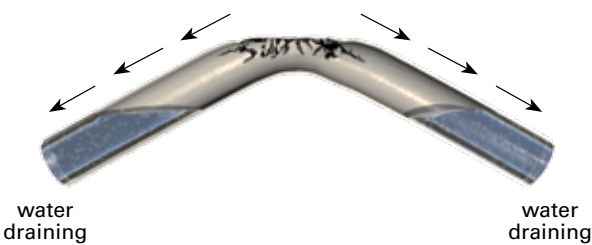

Sub atmospheric pressure is created due to pump shutdown or surges conditions

- Contaminants may be sucked into the system
- Thin-walled pipes may collapse
- Vapor pockets can form

After each stoppage of deep-well (borehole) pump, the riser drains from water and should be filled with air.

At startup, the water column in the pipe rises rapidly, and in the absence of an air-valve the pressurized air may be forced through the surface check-valve into the main header. Additionally, once the riser is full with water, the sudden increased resistance may cause pressure surges.

**Vertical Pump Discharge Without Air Valve**

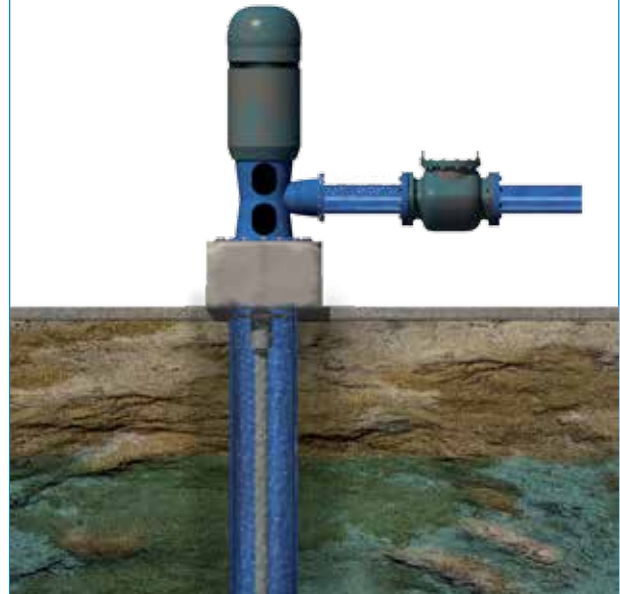

The riser of a deep-well pump is filled and drained with water when the pump is operated or stopped. Air must be admitted into and out of the riser.

- Surges in pipe column
- Entry of large volumes of air into the system
- Potential vacuum

**Primary Sources for Air in Water-Charged Pipelines**

- Atmospheric air that was trapped within the pipe-system when the pipeline was filled with water. With absence of air discharge devices, this would normally accumulate at local elevated points in the system or vent through customer tapping points.
- Water at normal pressure and temperature can contain approximately 2% (by volume) of dissolved air. The water flow is subjected to varying pressures and temperatures, due to the terrain slopes, variations in flow velocity caused by changing pipe diameters, partially-open valves, etc. and the dissolved air may be released from the water mass, accumulating as large pockets of air in the local peaks.
- Air may be drawn into the pipeline at start-up of deep-well pumps, by the pump suction-vortexes and through leaking joints at zones above the hydraulic gradients (negative- pressure points). Air can also be admitted into the system by air valves under sub-atmospheric pressure conditions.

## The Types and Functions of Air-Valves:

### Kinetic Air / Vacuum Valve:

- Exhaust large quantities of air from the pipeline when it is filled with water , at low pipeline pressure ("Kinetic" air-release function)
- Admit large quantities of air into the pipe when it is drained, or when the internal pressure drops below atmospheric pressure due to transient conditions ("Kinetic" anti-vacuum function)

### Automatic Air Release Valves:

- Release small pockets of accumulated air while the pipeline operates under pressure ("Automatic" air-release function)

### Combination Air Valves:

- A valve that perform the functions of both the "Kinetic" and "Automatic".

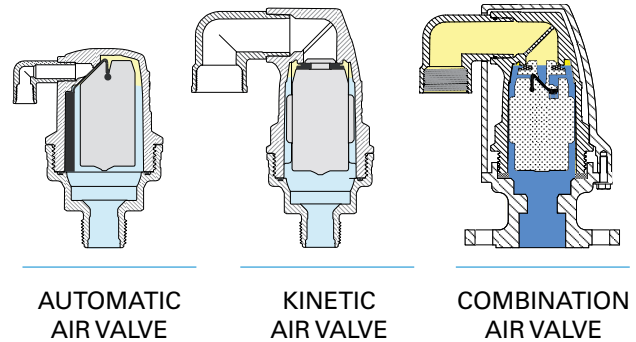

## Air Valve locations along a pipeline:

1. High points (relative to hydraulic gradient line).
2. Increase in a downward slope.
3. On uniform, long pipe sections: horizontal run, long descents. Air valves should also be located at even spaces of few hundreds of meters (500 to 1000), as determined by collapse-potential of the pipeline under negative pressure.
4. When the flow velocity is very low, air pockets may accumulate in each local peak, even in small ones, and in steep downhill slopes. It is recommended to eliminate these restrictions by installing air release valves.
5. On the discharge side of deep-well pumps and vertical turbine pumps.
6. Both sides of canal and bridge crossings.
7. Both sides of check-valves, isolating valves and any device that may be closed in the water system, where air may accumulates on one side while vacuum may be created on the other side.
8. Downstream of a pressure reducing device
9. At any point where the air may accumulate due to local pressure change.
10. At any point where sub-atmospheric conditions may occur during normal or transient conditions.

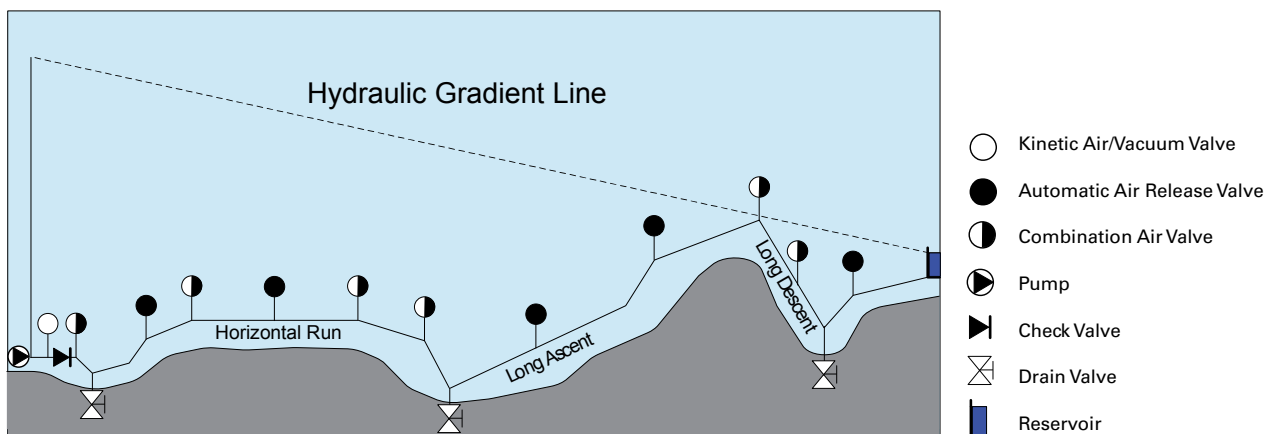

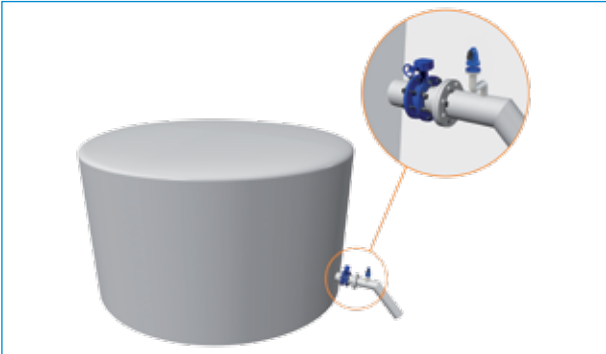

Outlet of reservoir, downstream of the isolation valve



Discharge side of pumps, upstream of a non return valve

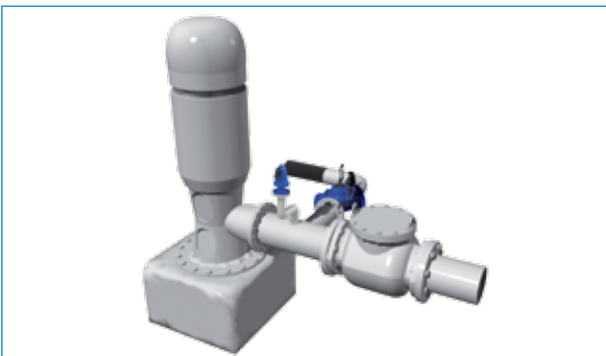

Discharge side of vertical turbine pumps, upstream of a non return valve

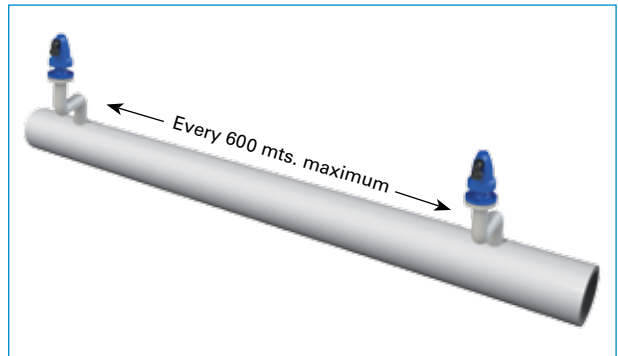

On uniform, long pipe sections: horizontal run, long descents, and long ascents



Negative breaks: increase in a downward slope



Adjacent to a pressure reducing device



Both sides of check-valves, isolating valves or any device that may be closed

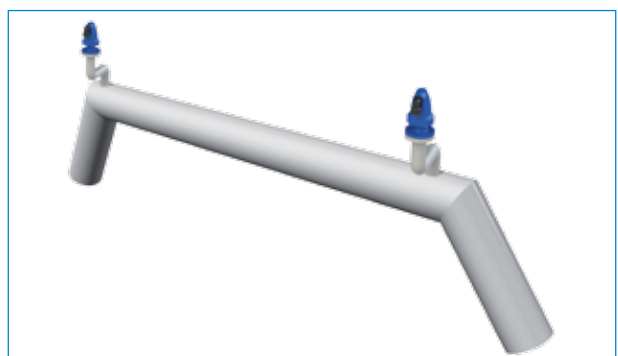

Both sides of canal and bridge crossings

## Sizing principles:

The volumetric air flow through the air valve is equal to the flow rate of the water filling or emptying the system:

For each volume of water entering the pipeline, the same volume of air must be expelled, and similarly, for each volume of water drained from the system, the same volume of air should be admitted into the line.

Note: Air is a compressible media, so its density and volume vary with the pressure. The term "volumetric flow" noted above, refers to the volume of air inside the pipeline. It is smaller than the 'standard' (atmospheric pressure) air flow when the system is being charged with water, and larger than the 'standard' flow when the system is being drained. The tables and charts presented in this catalogue present the standard air flow under atmospheric pressure.

The air flow velocity in the valve depends on three factors:

- Rate of water flow, at the valve site
- Orifice Diameter of the valve
- Geometry of the specific valve
- Pressure differential between the pipe and the atmosphere

The air flow-velocity through the valve can reach very high values, due to its low density. It is limited only when the velocity reaches the sonic speed, which is

practically impossible for the 'Kinetic' valve type, but is the normal situation in the case of the 'Automatic' valve type.

When the system's internal pressure reaches 0.89 barg, the volumetric air-flow through the orifice becomes constant (critical, sonic-velocity). Increase of the pressure will not result in increased volumetric-flow, though standard air-flow will continue to increase.

As a rule of thumb, the initial design value for air valves should allow maximal  $\Delta H$  of 0.1 barg across the valve. i.e. pipeline pressure which does not exceed 0.1 bar gauge-pressure while the pipe is filled, or -0.2 barg when it is drained.

However, each system must be inspected to its specific conditions, which the main one is the risk of collapse under sub-atmospheric pressures.

Too small orifice results in high air velocity that may cause:

- Premature closure, before the water reaches the valve
- A mechanical slam of the float to its seating area when the water has reached the valve, local water-hammer and possible breakage of the valve.
- Too-small air valve may cause too low sub-atmospheric pressure, which in turn may cause ingress of contaminants into the system and even pipe-collapse.

## Ordering Guide:

Ordering data	Ordering code						Ordering data
	DAV	MP	<input type="checkbox"/>	<input type="checkbox"/> <input type="checkbox"/> <input type="checkbox"/>	<input type="checkbox"/> <input type="checkbox"/>	SA	<input type="checkbox"/> <input type="checkbox"/>
			↑	↑	↑	↑	
<b>Size</b>							<b>Pressure Rating</b>
1/2" / 12 mm	→		1/2				PN16 ← PN16 / 230 psi
3/4" / 20 mm	→		3/4				PN25 ← PN25 / 360 psi
1" / 25 mm	→		1				<b>Optional Addition</b>
2" / 50 mm	→		2			SA	← Surge Arrestor *
<b>Connection Standard</b>					A		← <b>Function</b>
ISO 16, 25 *	→		ISO 16, 25, 40		K		← Kinetic
AN150, 300 *	→		ANSI 150, 300		KA		← Combination
BSP	→		BSP		KA		← Combination
NPT	→		NPT				

\* Available for 2" / 50mm only

### Example:

DAV	MP	3/4	BSP	A	PN16
-----	----	-----	-----	---	------

Dorot Metallic-Shield air-valve, size 3/4" (20mm) with BSP threaded connection and with 'Automatic' function for line pressure up to 16 bar



**DAV-MP-1-A**

**Automatic Air-Valve, Metallic-Shield**

This valve is designed for an efficient release of entrapped air from the pipeline, while the network is at normal working pressure.

Due to the relatively large orifice, compared to other Automatic valves in the market, it can also release the air through initial filling of a small-diameter pipe, or admit air into it while it is drained.

**Properties:**

An Automatic air valve, that enables the release of air that accumulates in the liquid-filled pipeline. The valve will release the air at normal operation pressures of the pipeline.

The Float is made of naturally-buoyant material (specific weight lower than 1) and activates a sealing stripe, that closes the outlet port when the water fills the valve body.

On accumulation of air in the valve, loss of buoyancy causes the float to drop and to pull the strip, thus opening the air outlet.

The Hydraulic sealing of the orifice will provide a drip-tight closure at a pressure as low as 2mwc (3psi).

**Operation:**

Releasing air from a pressurized pipeline. Small quantities of air accumulate in high peaks of the pipeline and in the body of the valve.

The descending water level allows the float to drop.



At a certain position the main float pulls down the seal, that partially opens the nozzle. The pressurized air can escape, the water level rises and the nozzle re-closes.

**Technical Specifications:**

- Operating pressure 0.1 bar / 1.5 psi to 25 bar / 360 psi
- 1" BSP or NPT threaded base - as per the customer's choice
- Cover material: Cast Iron  
Base material: Brass
- Internal parts: corrosion resistant, reinforced plastic materials and synthetic rubber

**Principle of operation:**

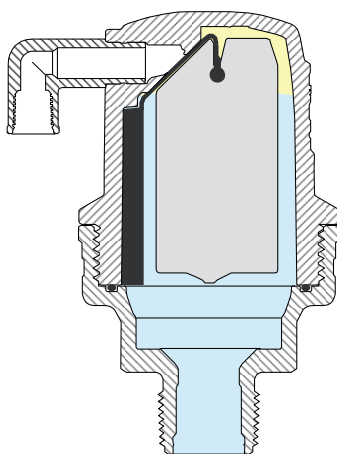

Pipe is full of water

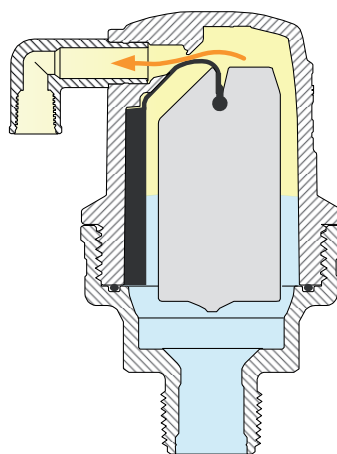

Pressurized air accumulated in the valve, is released when the float drops down

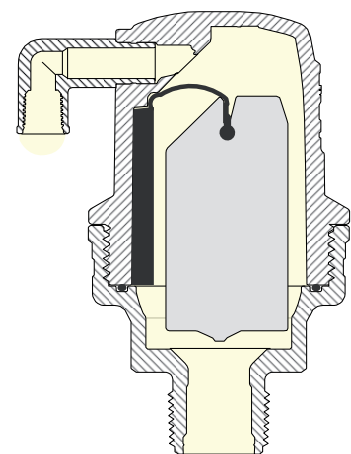

Pipe is aerated

### Parts list and specifications:

Part	Description	Material
1	Base	Brass
2	O ring	NBR
3	Automatic Float	Foamed Polypropylene
4	Automatic Seal	EPDM
5	Bonnet	PA6+30GF
6	Drainage Elbow	Polypropylene
7	ID Plate	AL
8	Metallic Cover	Cast Iron

### Dimensions:

Valve	25 mm / 1"	
	SI	US
H - Height	137 mm	5 <sup>3</sup> / <sub>8</sub> "
W - Width	99.5 mm	3 <sup>7</sup> / <sub>8</sub> "
D - Thread	1" BSP	1" NPT
A - Nozzle Area	12.85 mm <sup>2</sup>	0.02 in <sup>2</sup>
L - Total Width	116.5 mm	4 <sup>5</sup> / <sub>8</sub> "
E - Drainage Diameter	1/4" BSP	1/4" BSP
Weight	2 kg	4.3 lbs.

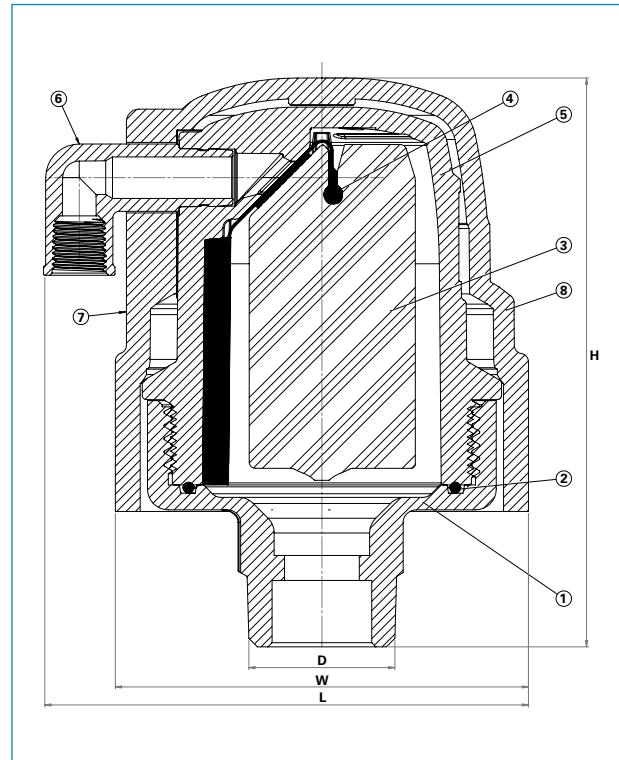

### Performance:

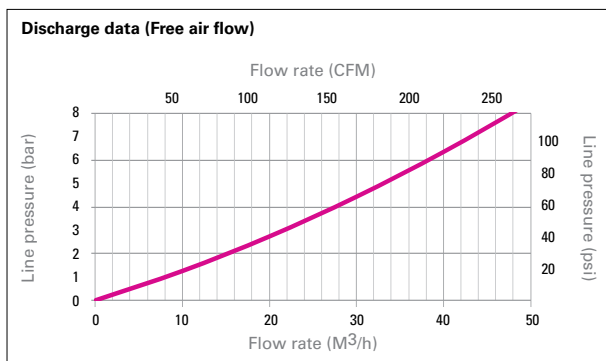

**DAV-MP-1-K****Kinetic Air-Valve, Metallic-Shield**

This valve has been designed for efficient discharge and intake of air in water pipelines, filtering systems, containers, and other places where confined air could impair the system's operation.

The valve is designed for:

- Releasing high volumes of air during the initial filling of the system
- Introducing large quantities of air when the pipe drains, maintaining atmospheric pressures in the pipe and preventing collapse and cavitation damage to the conduits

**Properties:**

Leak-proof sealing at all conditions, including low system pressure. The aerodynamic design of the float provides air flow at a very high velocity. The float will not close before the water has reached the valve. Threaded outlet elbow allows various possibilities of drain connection. The valve design contains a very limited number of parts, allowing easy dismantling for maintenance.

**Operation:**

The DAV-MP-K valve has two modes of operation:

- Discharge of large quantities of air at a high flow velocity when the conduit is being filled. When the water arrives to the valve, the float rises up and closes the outlet.
- Introduction of air into the pipeline when the internal pressure is sub-atmospheric. The pressure difference and the gravity, force the float to drop to "opened" position, allowing large volumes of air to flow into the pipe.

**Technical Specifications:**

- Operating pressure 0.1 bar / 1.5 psi to 25 bar / 360 psi
- 1" BSP or NPT threaded base - as per the customer's choice
- Cover material: Cast Iron
- Base Material: Brass
- Internal parts: corrosion resistant, reinforced plastic materials and synthetic rubber
- At pipe pressure of 0.5 bar / 7 psi:
  - The 2"/50mm valve allows the discharge of 260 m<sup>3</sup>/h / 153 CFM of air
  - The 1"/25mm valve allows the discharge of 60 m<sup>3</sup>/h / 35 CFM of air

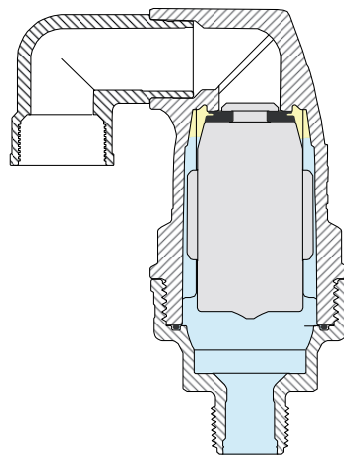
**Principle of operation:**

Pipe is full of water

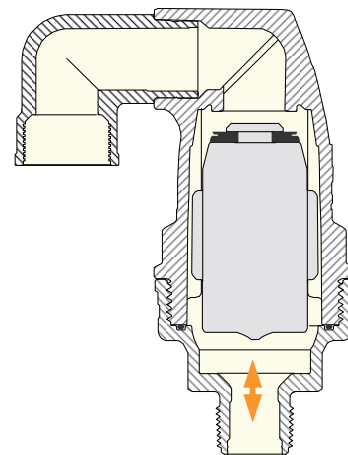

Pipe is aerated



### Parts list and specifications:

Part	Description	Material
1	Metallic Cover	Ductile iron (Optional SST)
2	Body	Brass
3	Bonnet	PA6+30GF
4	O ring	NBR
5	Drainage Elbow	Polypropylene
6	Float	Foam Polypropylene
7	Kinetic Seal	EPDM
8	ID Plate	AL

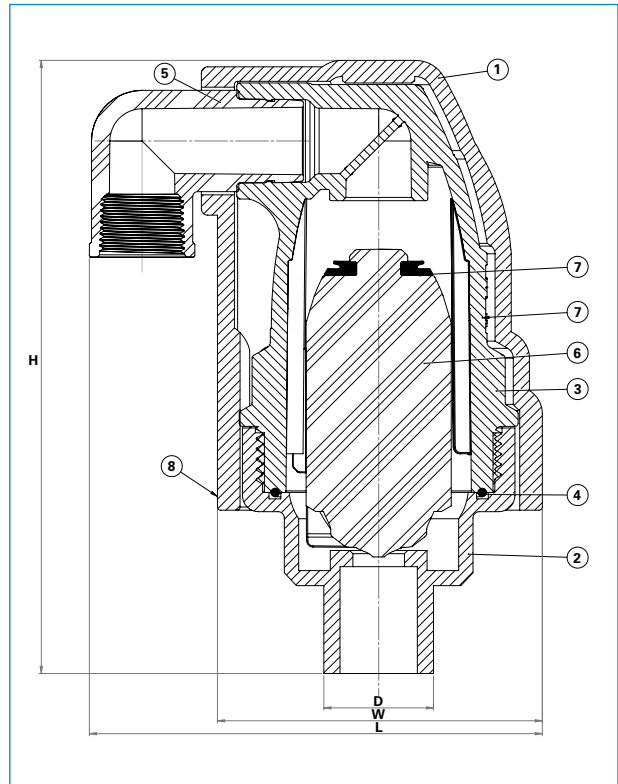

### Dimensions:

Valve	25 mm / 1"	
	SI	US
<b>H - Height</b>	190 mm	7 1/2"
<b>W - Width</b>	100 mm	3 7/8"
<b>D - Thread</b>	1" BSP	1" NPT
<b>K-Kinetic Nozzle Area</b>	314 mm <sup>2</sup>	0.49 in <sup>2</sup>
<b>L - Total Width</b>	140 mm	5 1/2"
<b>E - Drainage Diameter</b>	3/4" BSP	3/4" BSP
<b>Weight</b>	2.6 kg	5.60 lbs.

### Performance:

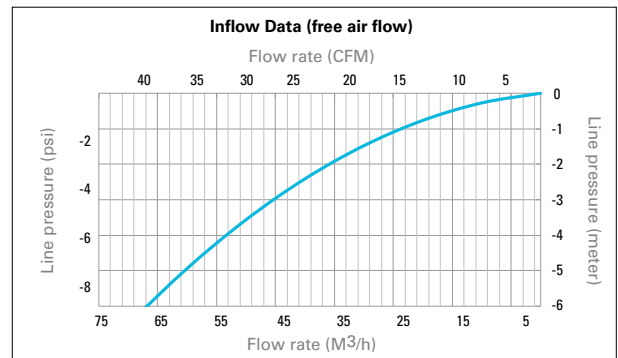
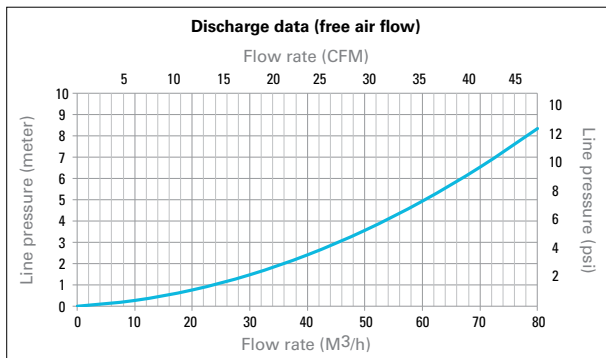

**DAV-MP-1-KA**

**Combination Air-Valve, Metallic-Shield**

This valve has been designed for efficient discharge and intake of air in water pipelines, filtering systems, containers, and other places where confined air could impair the system’s operation. The valve is designed for:

- Discharge of high air-volumes during the initial filling of the systems
- Introducing large quantities of air when the pipe drains, maintaining atmospheric pressure in the pipe and preventing collapse and cavitation damage to the conduits
- Relieving air from the water-filled system, while the network is pressurized

**Properties:**

Leak-proof sealing at all conditions, including low system pressure. The aerodynamic design of the float provides air flow at a very high velocity. The float does not close before the water has reached the valve. Threaded outlet elbow allows various possibilities of drain connection. The valve design contains a very limited number of parts, allowing easy dismantling for maintenance.

**Operation:**

The DAV-P-1-KA valve has three modes of operation:

- Discharge of large volumes of air at a high flow velocity when the conduit is being filled. When the water arrives at the valve, the main float rises and closes the outlet.
- Introduction of air into the pipeline when the internal pressure is sub-atmospheric. The pressure differential and the gravity, force the main float to drop to “opened” position, allowing the air to flow into the pipe.
- Releasing air from the pressurized, water-filled pipeline. Small quantities of air accumulate at high peaks of the pipeline and in the body of the valve. The descending water level allows the float to drop. At a certain position the main float pulls down the small



seal, that partially opens the nozzle. The pressurized air can escape, the water level rises and the nozzle re-closes.

- Introduction of air into the pipeline when the internal pressure is sub-atmospheric. The pressure difference and the gravity, force the float to drop to “opened” position, allowing large volumes of air to flow into the pipe.

**Technical Specifications:**

- Operating pressure 0.1 bar / 1.5 psi to 25 bar / 360 psi
- 1” BSP or NPT threaded base - as per the customer’s choice
- Cover material: Cast Iron
- Base Material: Brass
- Internal parts: corrosion resistant, reinforced plastic materials and synthetic rubber
- At pipe pressure of 0.5 bar / 7 psi:
  - The 2”/50mm valve allows the discharge of 260 m³/h / 153 CFM of air
  - The 1”/25mm valve allows the discharge of 60 m³/h / 35 CFM of air

**Principle of operation:**

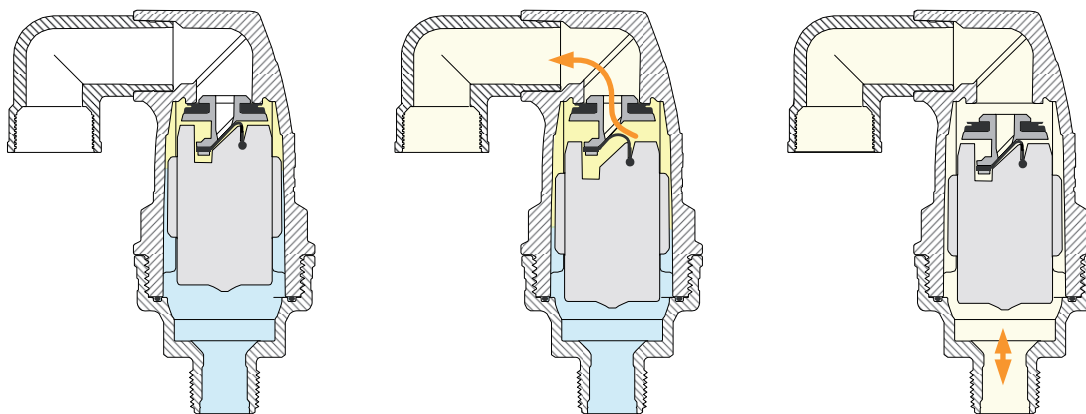

Pipe is full of water

Pressurized air accumulated in the valve, is released when the float drops down

Pipe is aerated

## Parts list and specifications:

Part	Description	Material
1	Metallic Cover	Ductile iron (Optional SST)
2	Base	Brass (optional SST)
3	Bonnet	PA6+30GF
4	O-ring seal	NBR
5	Drainage Elbow	PP
6	Float	Foamed PP
7	Automatic Seal	EPDM
8	Kinetic Seal	EPDM
9	Spacer	POM
10	Slider	PA GF
11	ID Plate	AL

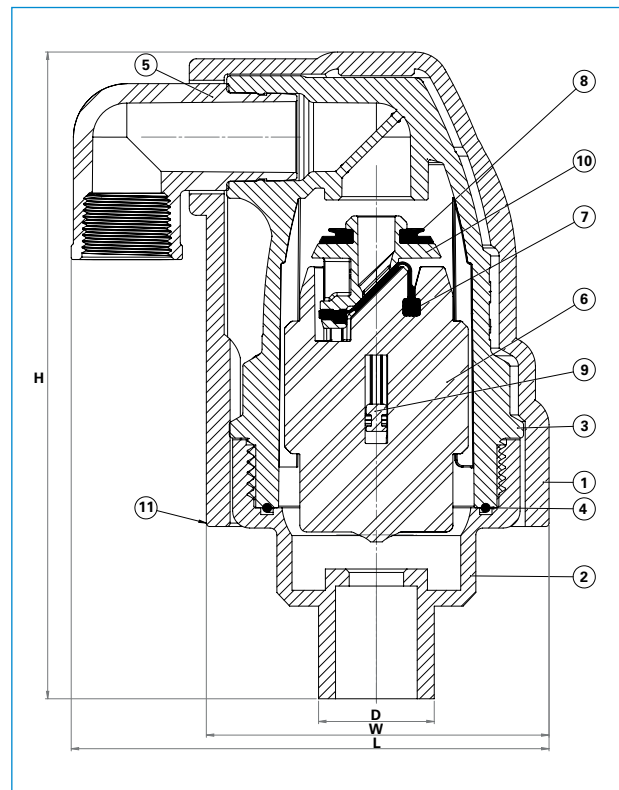

## Dimensions:

Valve	25 mm / 1"	
	SI	US
<b>H - Height</b>	190 mm	7 1/2"
<b>W - Width</b>	100 mm	3 7/8"
<b>D - Thread</b>	1" BSP	1" NPT
<b>A - Nozzle Area</b>	12.85 mm <sup>2</sup>	0.02 in <sup>2</sup>
<b>K-Kinetic Nozzle Area</b>	314 mm <sup>2</sup>	0.49 in <sup>2</sup>
<b>L - Total Width</b>	140 mm	5 1/2"
<b>E - Drainage Diameter</b>	3/4" BSP	3/4" BSP
<b>Weight</b>	2.6 kg	5.60 lbs.

## Performance:

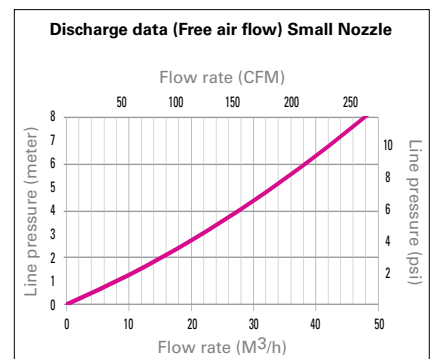
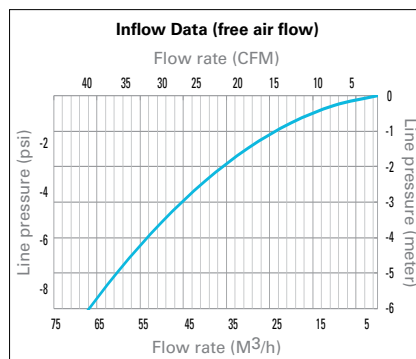
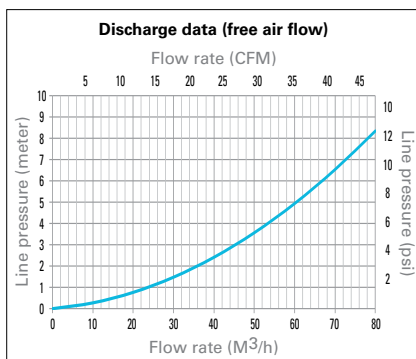

**DAV-MP-2-KA****Combination Air-Valve, Metallic-Shield**

This valve has been designed for efficient discharge and intake of air in water pipelines, filtering systems, containers, and other places where confined air could impair the system's operation.

The valve is designed for:

- Discharge of high air-volumes during the initial filling of the systems
- Introducing large quantities of air when the pipe drains, maintaining atmospheric pressure in the pipe and preventing collapse and cavitation damage to the conduits
- Relieving air from the water-filled system, while the network is pressurized

**Properties:**

Leak-proof sealing at all conditions, including low system pressure. The aerodynamic design of the float provides air flow at a very high velocity. The float does not close before the water has reached the valve. Threaded outlet elbow allows various possibilities of drain connection. The valve design contains a very limited number of parts, allowing easy dismantling for maintenance.

**Operation:**

The DAV-P-2-KA valve has three modes of operation:

- Discharge of large volumes of air at a high flow velocity when the conduit is being filled. When the water arrives to the valve, the main float rises and closes the outlet.
- Introduction of air into the pipeline when the internal pressure is sub-atmospheric. The pressure differential and the gravity, force the main float to drop to "opened" position, allowing the air to flow into the pipe.
- Releasing air from the pressurized, water-filled pipeline. Small quantities of air accumulate at high peaks of the pipeline and in the body of the valve. The descending



water level allows the float to drop. At a certain position the main float pulls down the small seal, that partially opens the nozzle. The pressurized air can escape, the water level rises and the nozzle re-closes.

- Introduction of air into the pipeline when the internal pressure is sub-atmospheric. The pressure difference and the gravity, force the float to drop to "opened" position, allowing large volumes of air to flow into the pipe.

**Technical Specifications:**

- Operating pressure 0.1 bar / 1.5 psi to 25 bar / 360 psi
- 2" Threaded/Flanged base - as per the customer's choice
- Cover material: Ductile Iron
- Base Material: Ductile Iron
- Internal parts: corrosion resistant, reinforced plastic materials and synthetic rubber
- The valve allows the discharge of 450m<sup>3</sup>/h of air at a line pressure of 0.9 bar, when fully-open

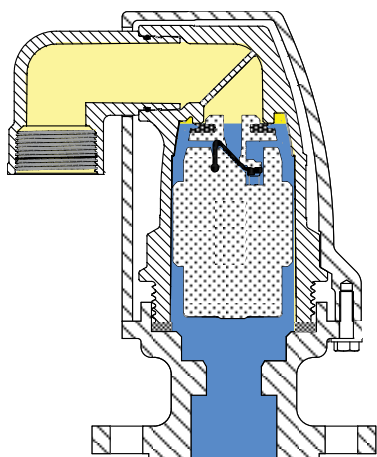
**Principle of operation:**

Pipe is full of water

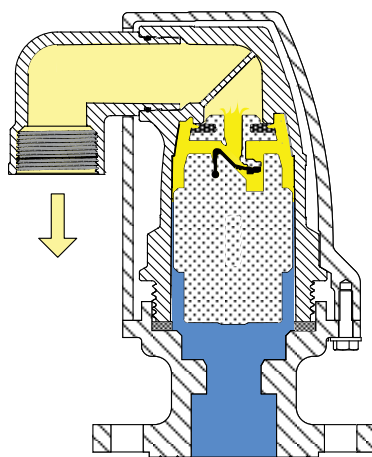

Pressurized air accumulated in the valve, is released when the float drops down

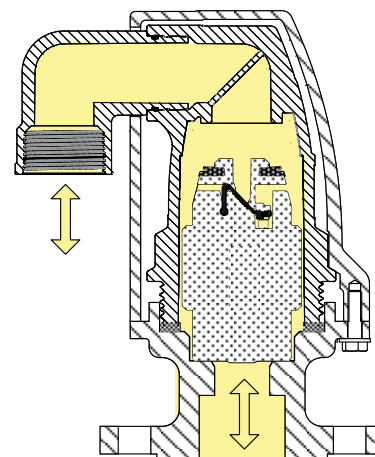

Pipe is aerated

### Parts list and specifications:

Part	Description	Material
1	Bonnet	PA6+30GF
2	Cover	D.I
3	Flanged Base	D.I
4	Elbow	Polypropylene
5	Float	Foam PP
6	Slider	PA6+30GF
7	Seal	EPDM
8	Spacer	POM
9	Auto Seal	EPDM
10	Flat Seal	EPDM
11	O Ring	Nitrilic Rubber
12	ID Plate	Aluminium
13	Screw Hex	SST
14	Washer	SST

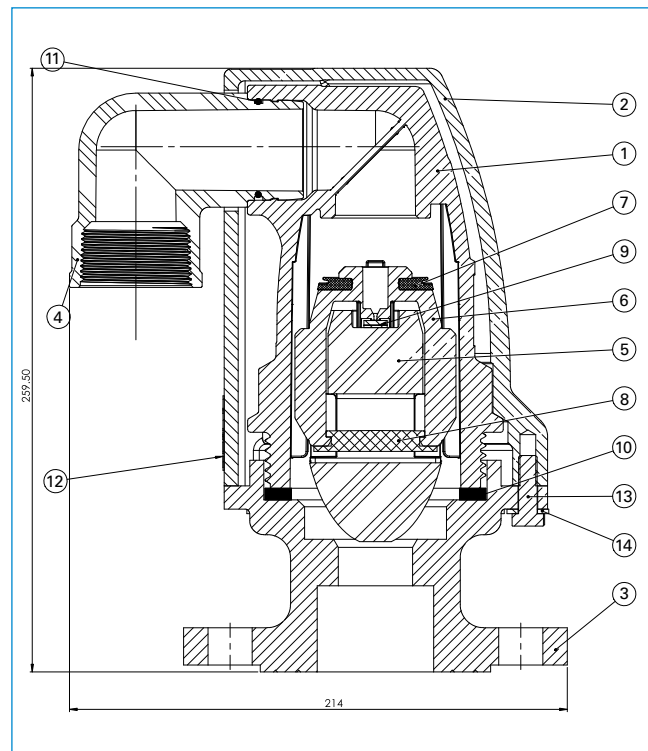

### Dimensions:

Valve	50 mm / 2"	
	SI	US
H - Height	259.5 mm	10 <sup>3</sup> / <sub>16</sub> "
Total Width	214 mm	8 <sup>3</sup> / <sub>8</sub> "
D - Thread	2" BSP	2" NPT
A - Nozzle Area	12.85 mm <sup>2</sup>	0.02 in <sup>2</sup>
K - Kinetic Nozzle Area	908 mm <sup>2</sup>	1.41 in <sup>2</sup>
Flange	ISO16/25	ANSI150
E - Drainage Diameter	1 <sup>1</sup> / <sub>2</sub> " BSP	1 <sup>1</sup> / <sub>2</sub> " BSP
Weight	9 kg	19.8 lbs.

### Performance:

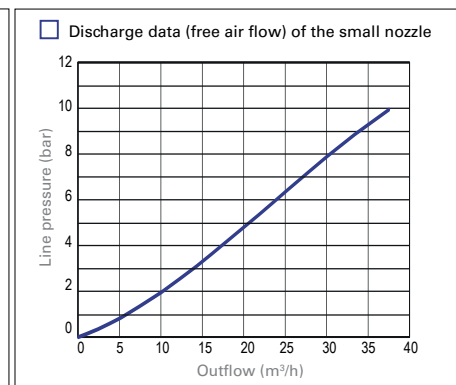
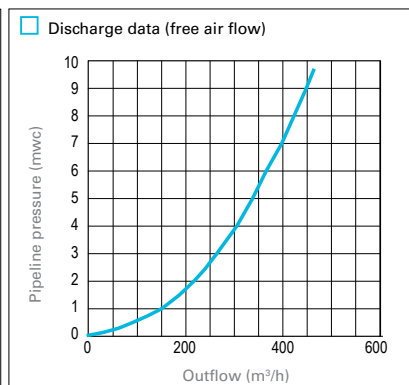
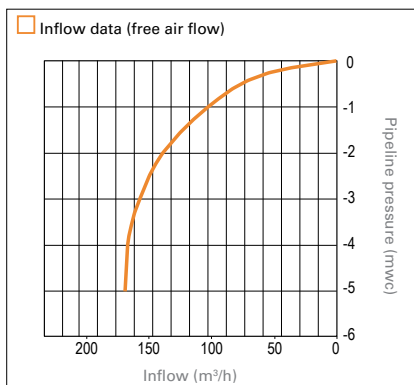



**DAV-MP-SA**  
**Surge arresting device for DAV valves**

**Features:**

- **Surge Arresting** - Automatically prevents water hammer pressure surges associated with air release valves operation.
- **Optimum performance** - Air outlet can be adjusted according to surge analysis results, on site to a required aero-dynamic performance. The SA addition is assembled on user selected valves only (at local high elevated points). The flow through other valves remains unrestricted.
- **Reliability** - Simple, durable mechanism, Can be serviced without having to put the air valve out of service.



**Operation:**

When air is admitted into the pipe, an in "Air Pocket" is created in the local high points where the Air / Vacuum valve is located. The returning flow re-fills the "pocket". Too-high velocity of the approaching water column may generate a pressure surge when it reaches the valve.

**Air venting**

The Surge Arrestor addition of "DAV-MP" valves limits the air outflow, when the escaping air velocity exceeds a threshold value.

This optional addition creates a temporary, slow closing "Air Cushion" that decelerates the water velocity, preventing water hammer effect.

**Vacuum Breaking (Air Intake)**

Decrease or the pressure in the system to negative value and the simultaneous drainage of the valve chamber, forces the floats down, allowing the admittance of air into the pipe. The SA disc moves back and allowing unrestricted air flow into the system.

**Principle of operation:**

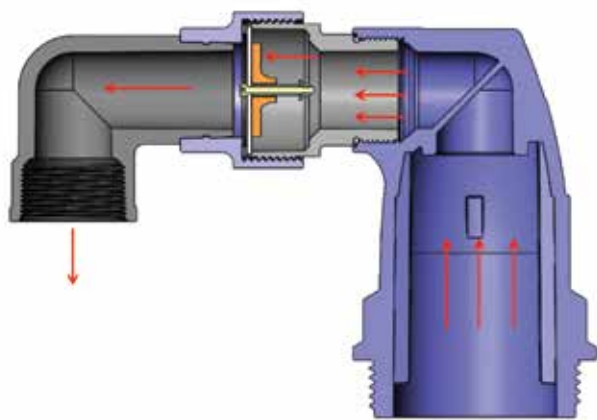

Air venting

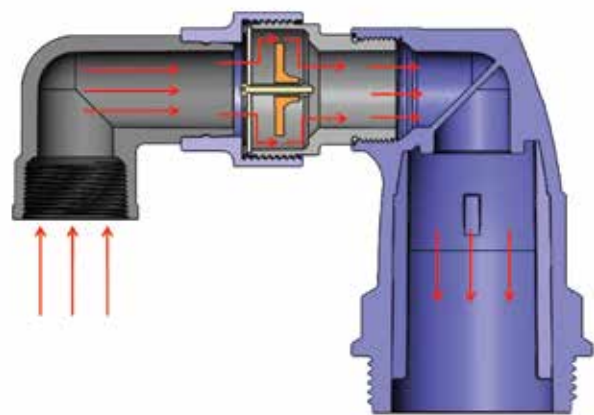

Vacuum Breaking (Air Intake)

### Dimensions:

Valve	DAV-P-SA	
	SI	US
<b>H - Height</b>	70 mm	2 <sup>11</sup> / <sub>16</sub> "
<b>W - Width</b>	98 mm	3 <sup>13</sup> / <sub>16</sub> "

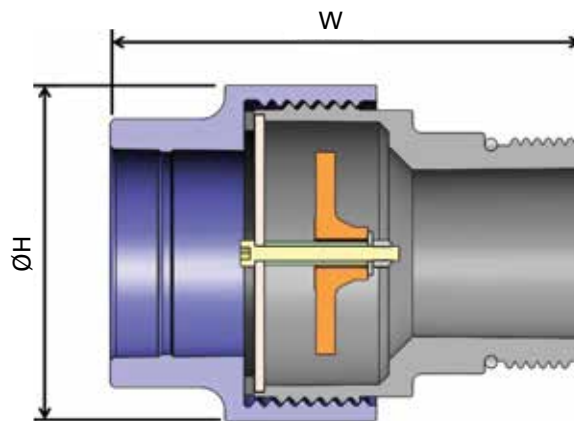

### Aerodynamic Performance





**Innovation**  
Innovation

**Expertise**  
Expertise

**Reliability**  
Reliability



Hundreds of companies in the industrial, civil engineering, municipal and agricultural sectors around the world have chosen DOROT's innovative and field-proven technologies. Since its establishment in 1946, DOROT leads the valves market with continued innovation, uncompromising excellence and firm commitment to its customers, consulting and supporting them through all stages of a project and overcoming challenges in R&D, design, implementation, and maintenance.



**AVFI Pty Ltd**  
T: 1300 789 256  
E: [avfi@avfi.com.au](mailto:avfi@avfi.com.au)  
W: [www.avfi.com.au](http://www.avfi.com.au)  
**Sales Offices:**  
ACT, QLD, NSW, NT,  
SA, TAS, VIC, WA & NZ