

VT-NE SERIES

CLASS 6000 PSI NEEDLE VALVE
316 STAINLESS STEEL

TECHNICAL DATA

Size Range:	DN6 - DN25 (1/8" - 1")
Pressure Rating:	6000 PSI W.O.G
Features:	<ul style="list-style-type: none"> • Investment casting body • Screwed-in bonnet • Rising stem • T handle operation • Conneting Threads: ANSI B2.1, BS21, DIN 259/2999, ISO 228.

MATERIAL SPECIFICATIONS & PARTS LIST

NO.	DESCRIPTION	MATERIAL
1	Body	SS316
2	Body Seal	PTFE
3	Disc	SS316
4	Stem	SS316
5	Bonnet	SS316
6	Packing	PTFE
7	Gland	SS316
8	Packing Nut	SS316
9	Handle	SS410
10	Fixing Screw	Alloy Steel

DIMENSIONS (MM)

VT-NE DN6 - DN25												
DN	NPS	FxF	H	h1	ØI	ØI1	ØI2	W	Øw	CV Factor	Weight (Kg)	
6	1/8"	45	82	65	60	7	3	22	13	0.4	0.35	
8	1/4"	45	82	65	60	7	3	22	13	0.4	0.35	
10	3/8"	50	85	67	60	7	3	25	13	0.4	0.35	
15	1/2"	60	107	86	65	8	5	30	16	0.75	0.56	
20	3/4"	65	111	88	65	8	5	35	16	0.9	0.70	
25	1"	83	130	100	80	10	7	46	19	1.8	1.30	

FACTORY ACCREDITED:

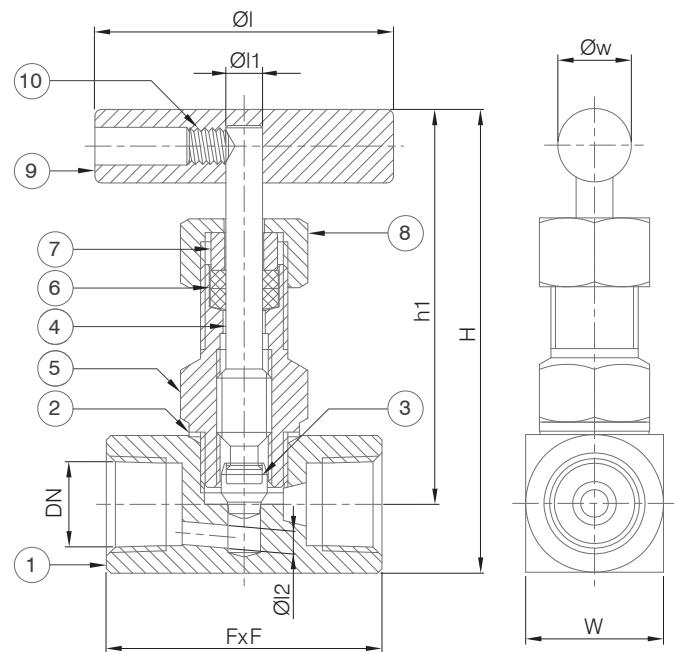
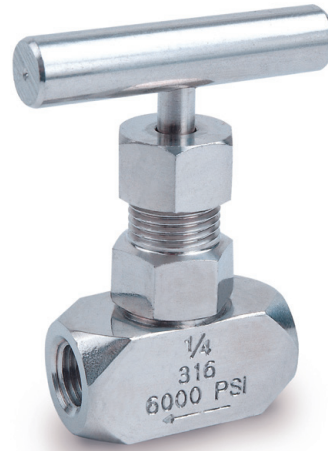

PRESSURE RATINGS

